

lama box angolo vetro fisso
 lama shower enclosure corner sliding door
 lama Eck-Duschkabine mit Schiebetür

fasì di montaggio
 assembly steps
 Montage-Schritte

verifica di cantiere
 check on site
 vorbereitende Kontrollen

compensazione fuori piombo
 compensation of level differences
 Schrägen ausgleichen

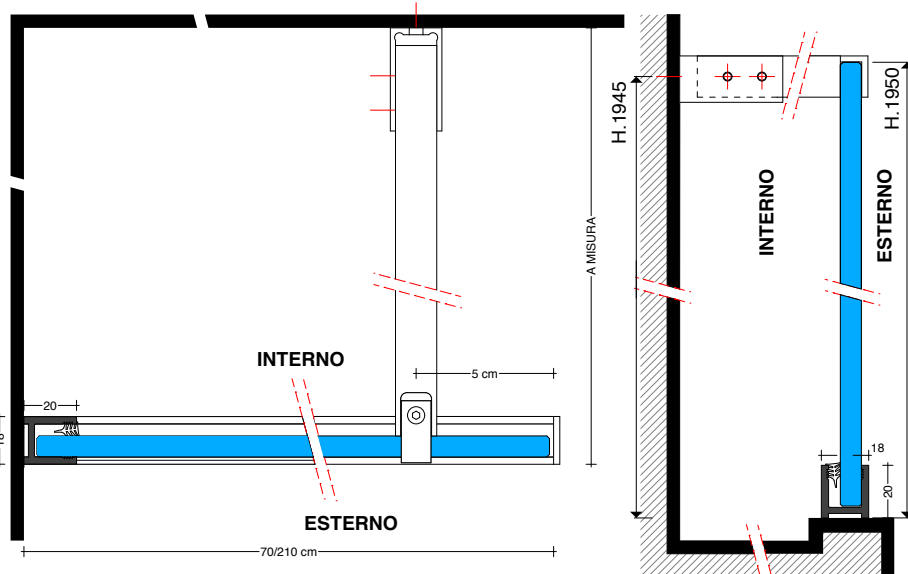
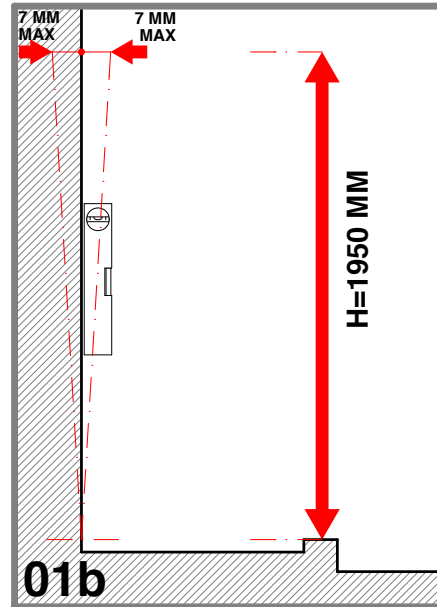
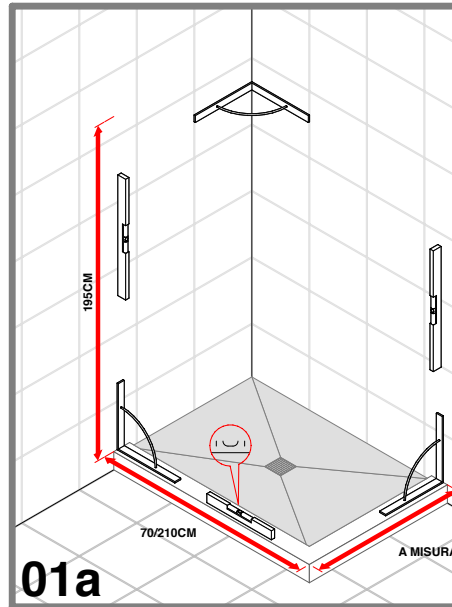
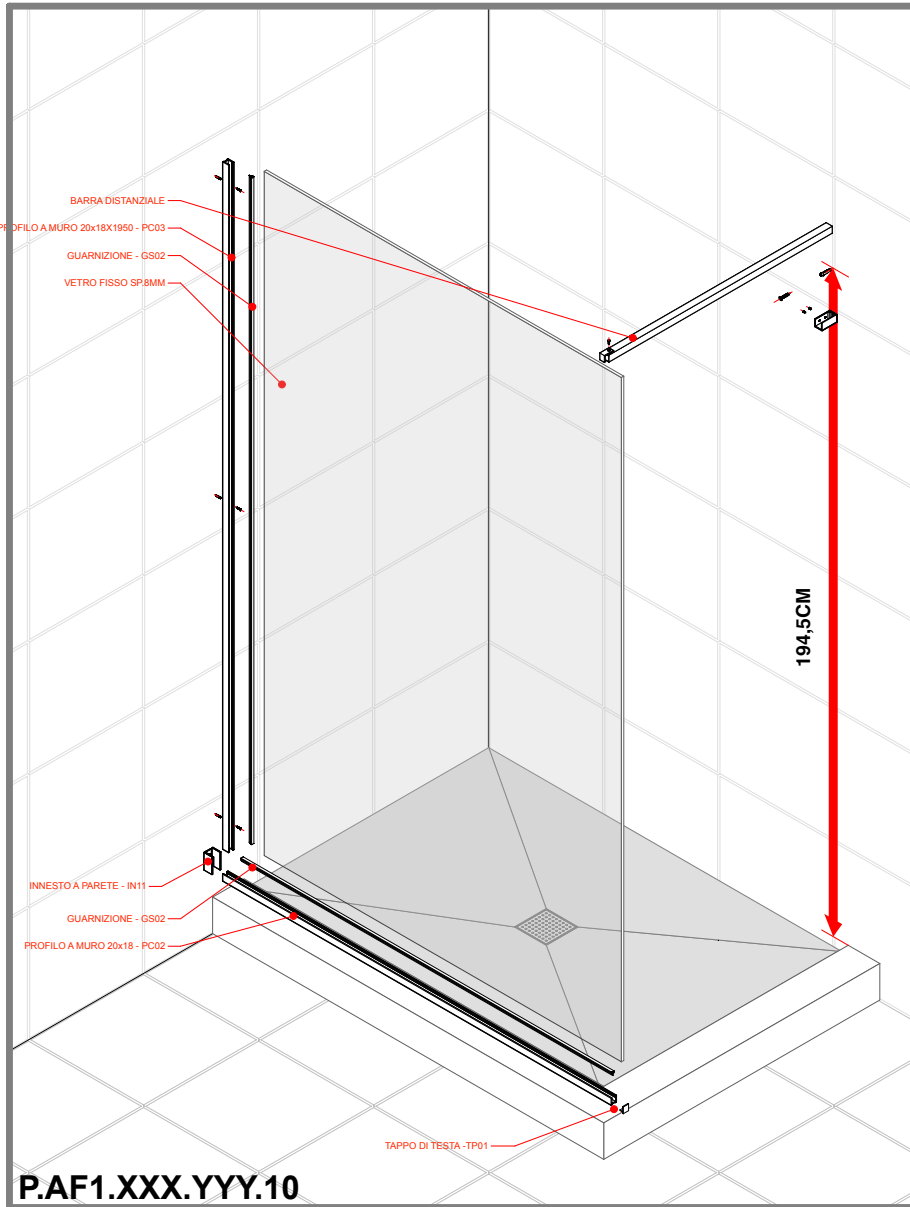

posa e incollaggio con silicone del telaio inferiore
positioning and fixing of the lower profiles with silicon
Positionieren und Aufkleben der Bodenprofile mit Silikon

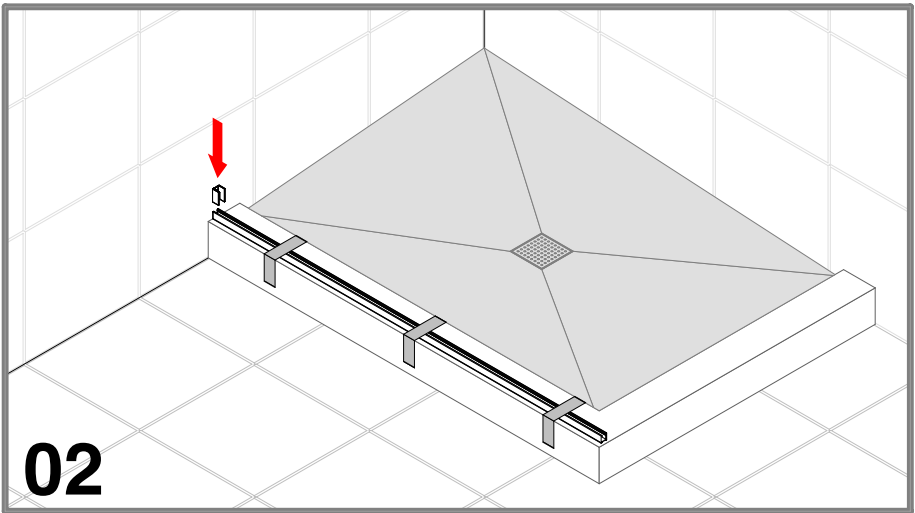
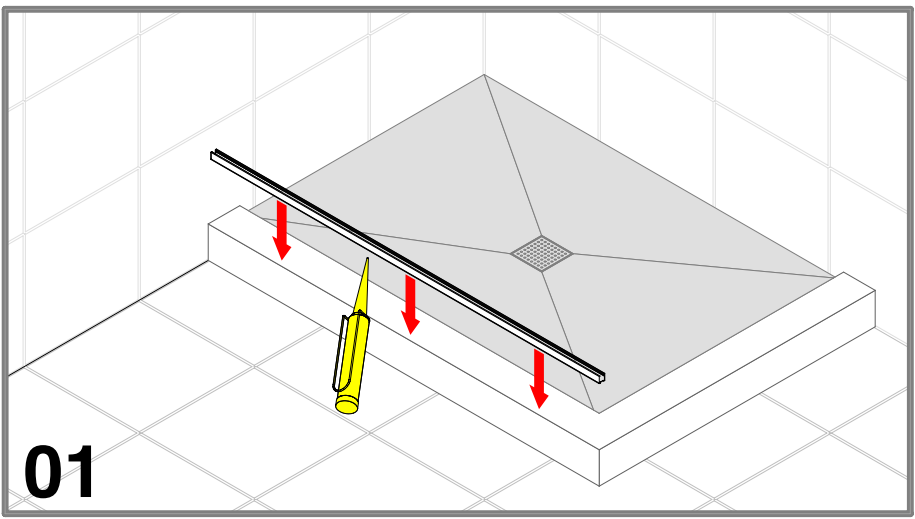

foratura pareti, montaggio vetro fisso e guarnizione
boring walls, assembly fixed glass panels and gaskets
Montage feststehende Glaswände und Dichtungen

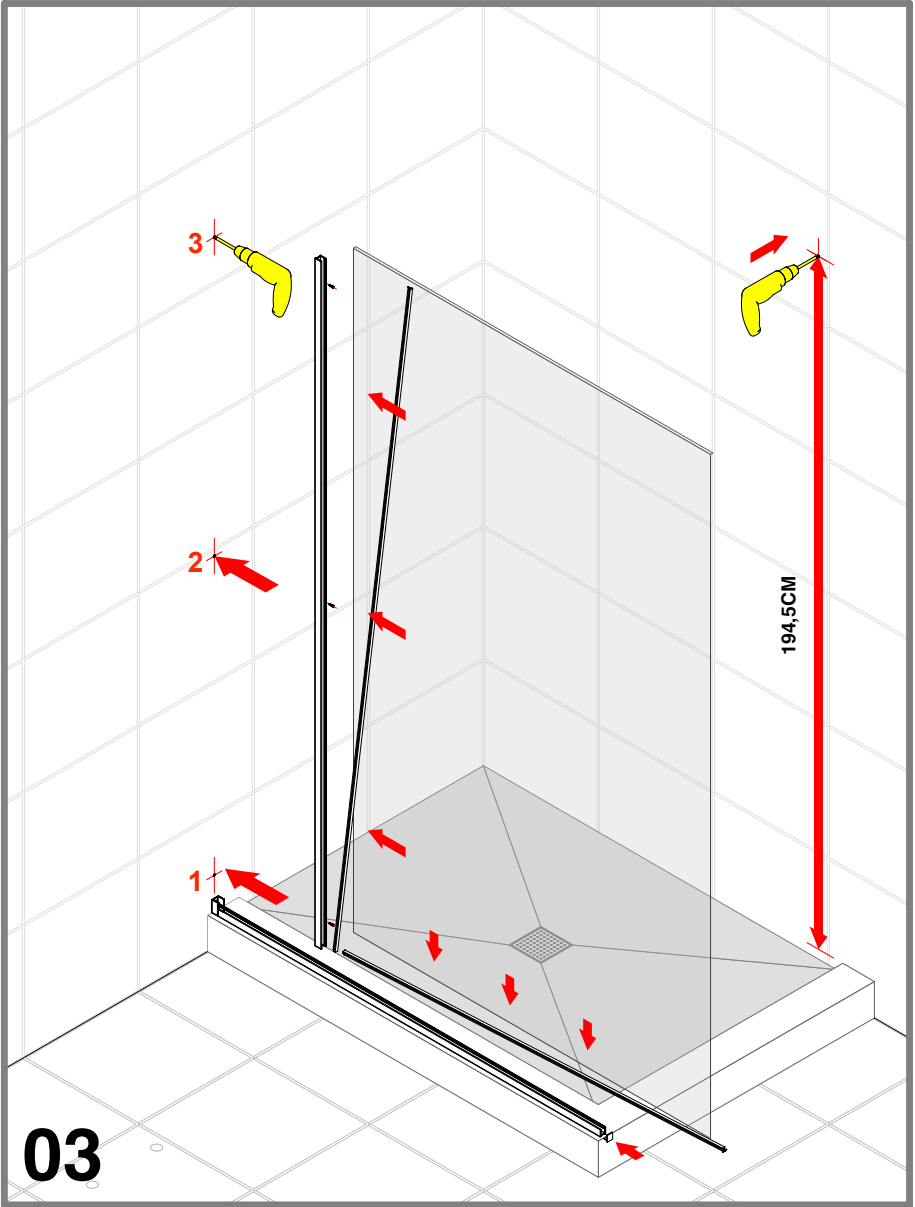

montaggio barra
assembly bar
Montage bar

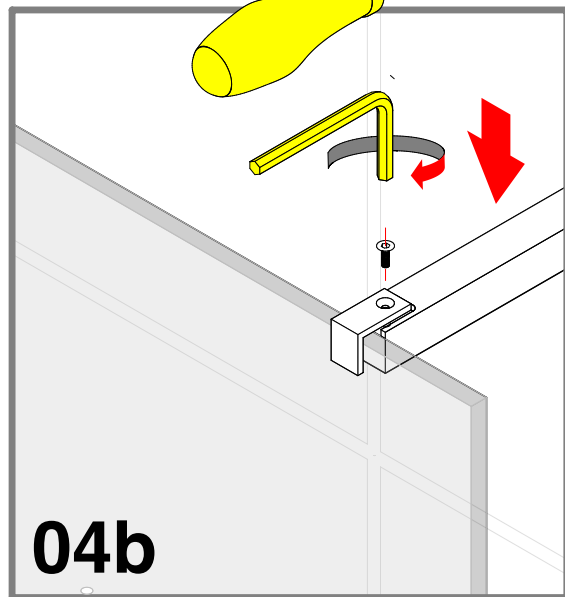
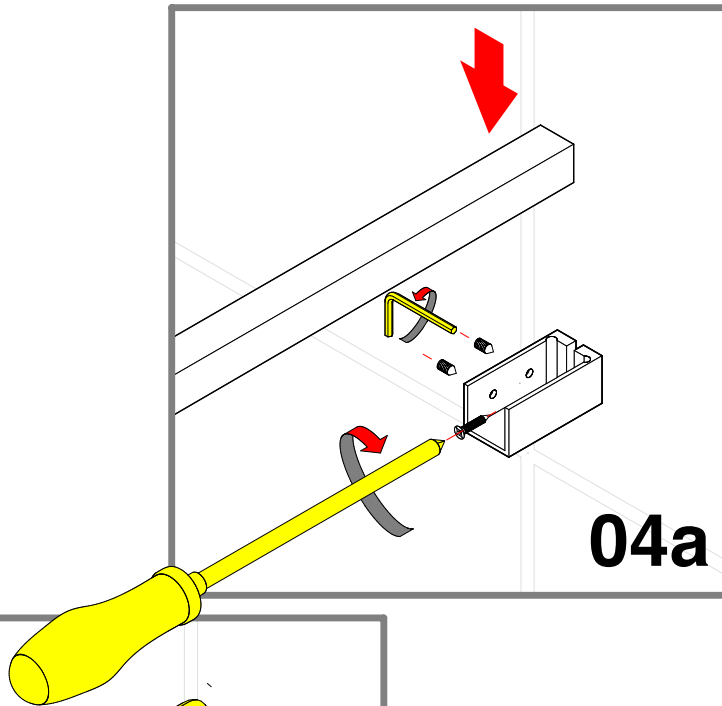

montaggio vetro fisso e barra - siliconatura
assembly of the fixed glasses and bar - silicone
Montage der Tür - befestigen - silikonieren

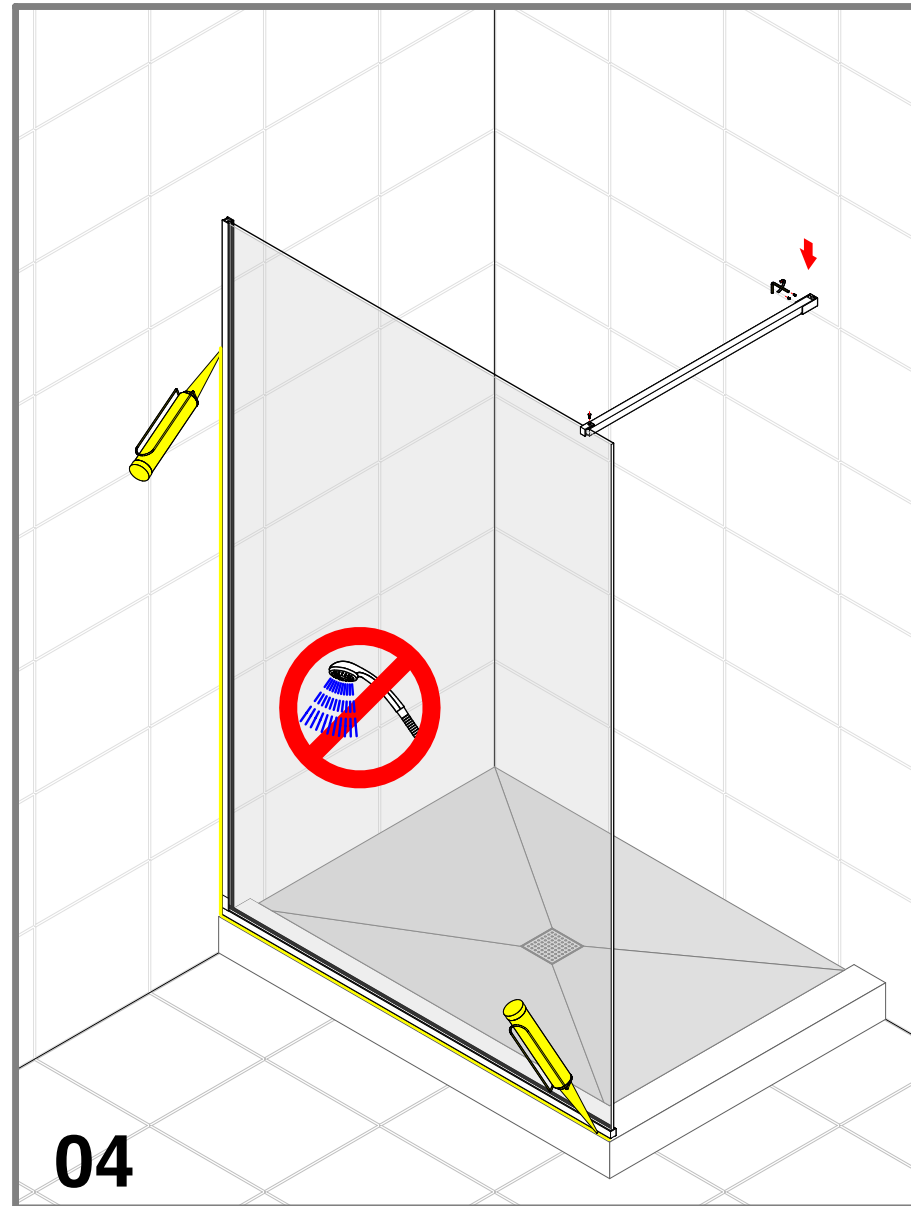

lama box nicchia vetro fisso
 lama shower enclosure corner sliding door
 lama Eck-Duschkabine mit Schiebetür

fasi di montaggio
 assembly steps
 Montage-Schritte

verifica di cantiere
 check on site
 vorbereitende Kontrollen

compensazione fuori piombo
 compensation of level differences
 Schrägen ausgleichen

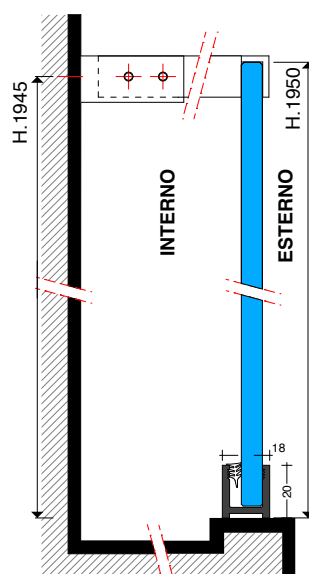
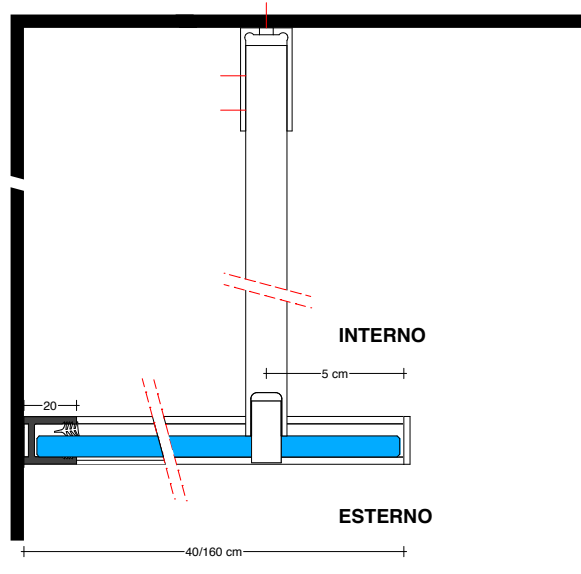
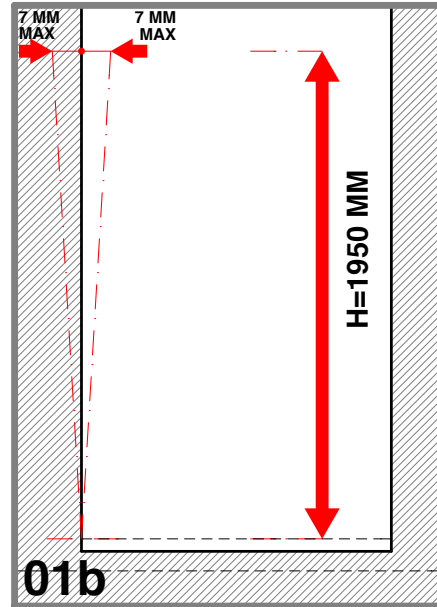
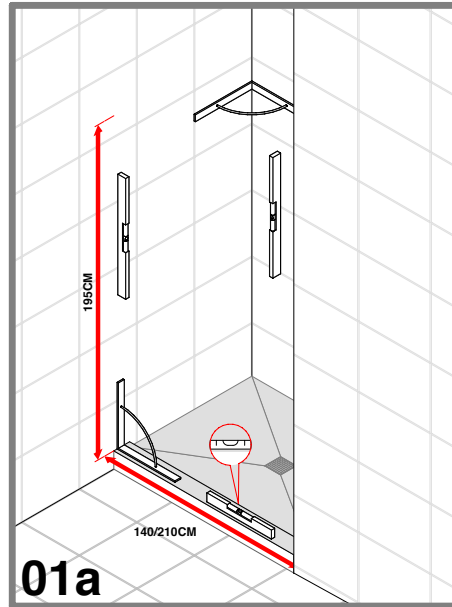
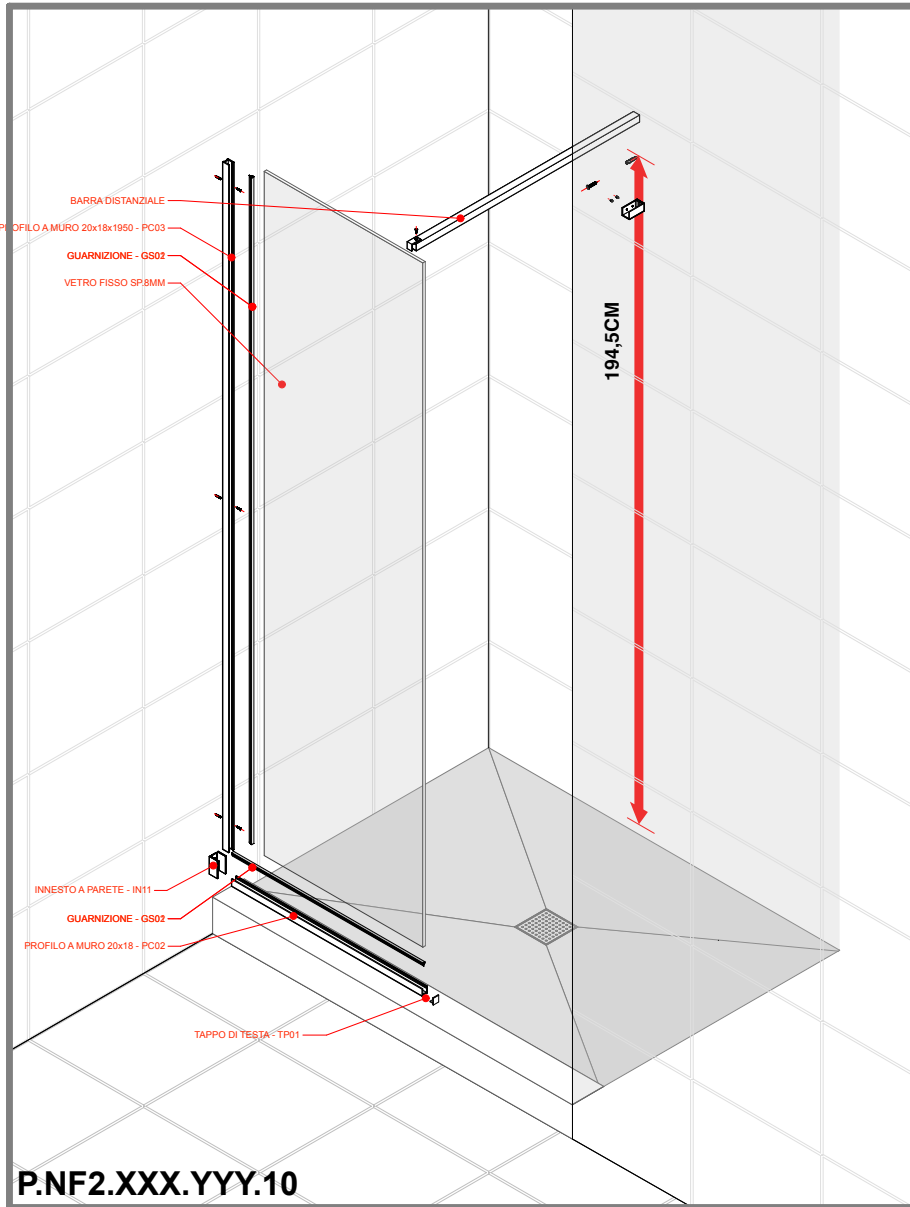

posa e incollaggio con silicone del telaio inferiore
positioning and fixing of the lower profiles with silicon
Positionieren und Aufkleben der Bodenprofile mit Silikon

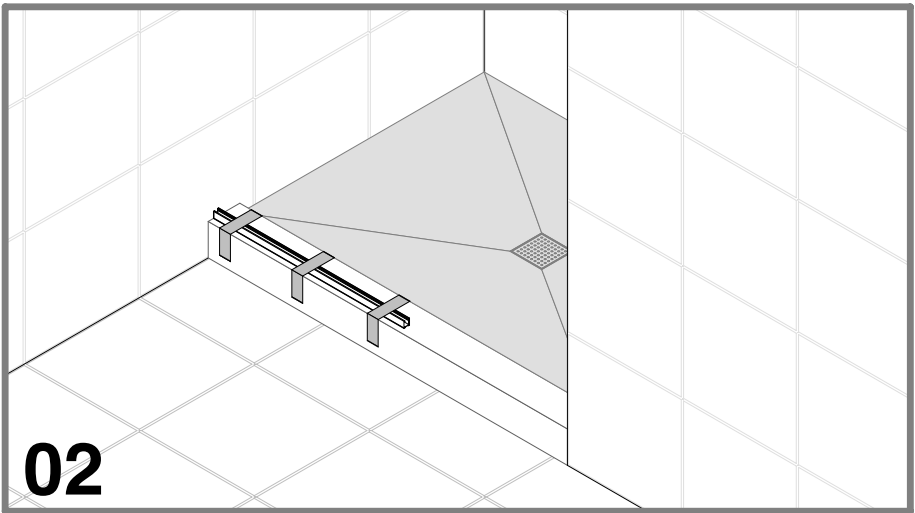
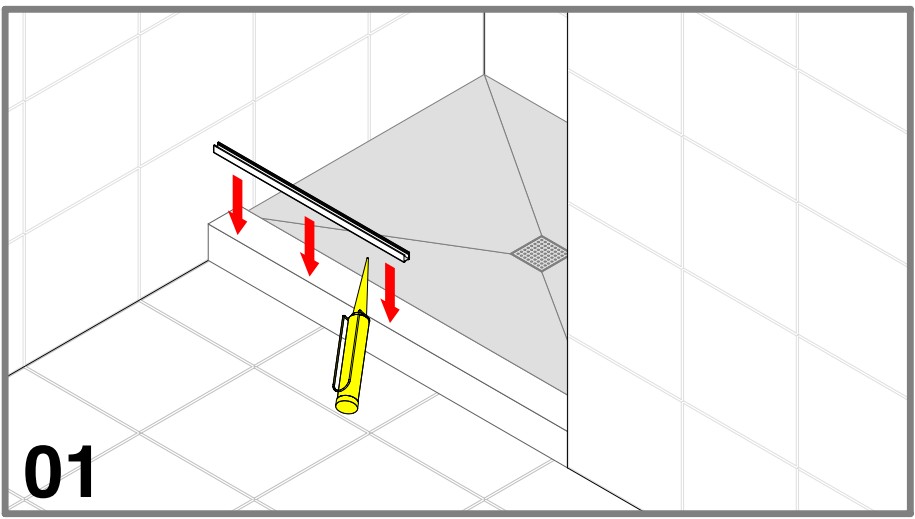

foratura pareti, montaggio vetro fisso e guarnizione
boring walls, assembly fixed glass panels and gaskets
Montage feststehende Glaswände und Dichtungen

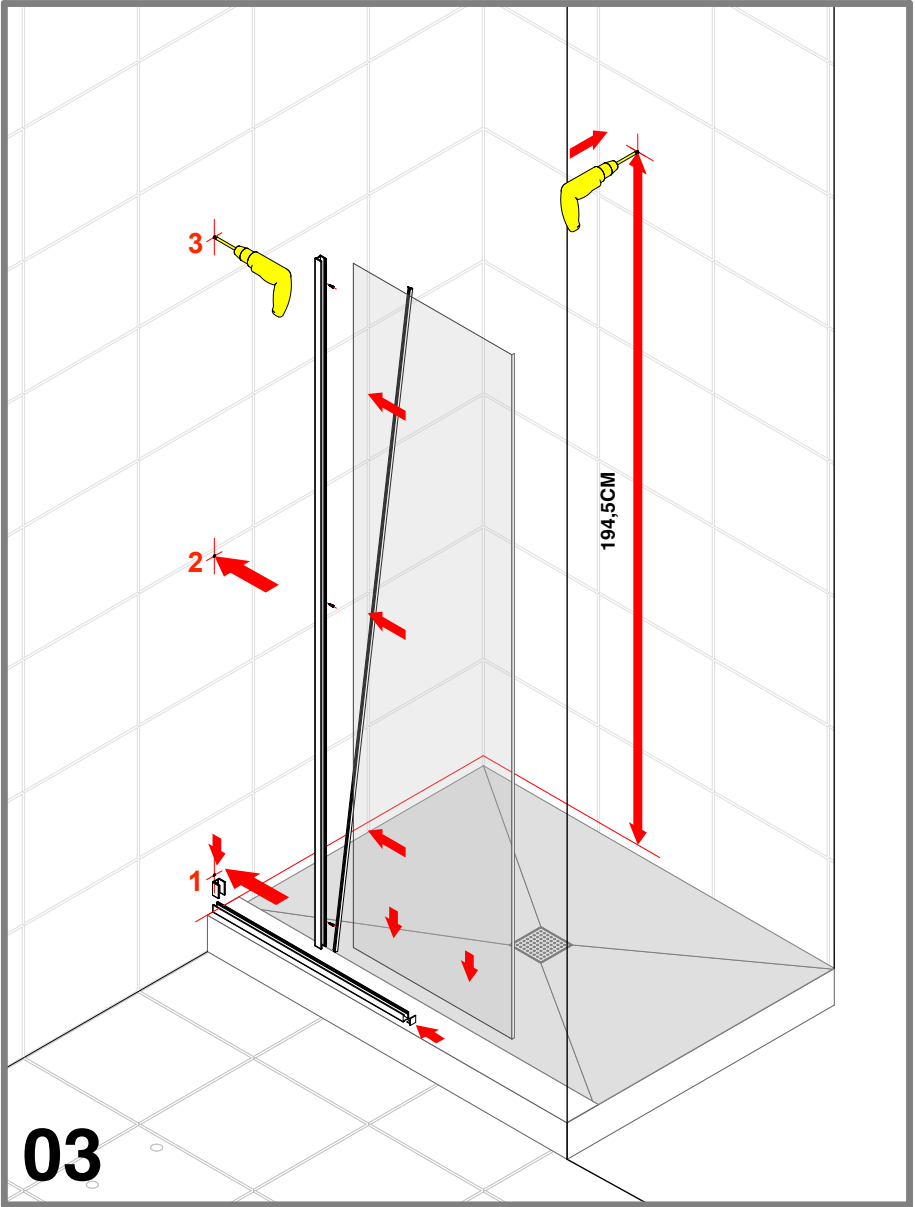

montaggio barra
assembly bar
Montage bar

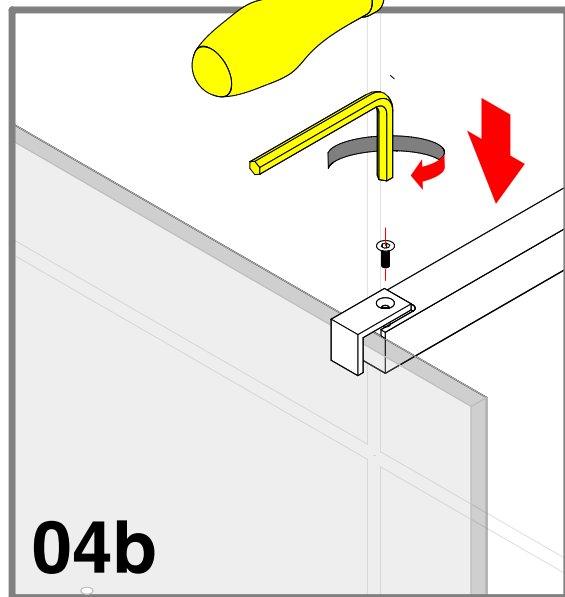
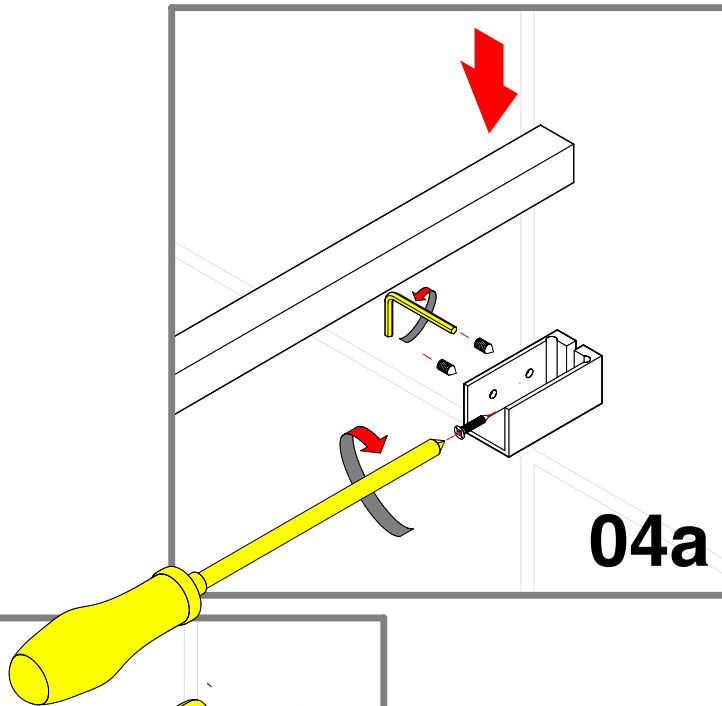

montaggio vetro fisso e barra - siliconatura
assembly of the fixed glasses and bar - silicone
Montage der Tür - befestigen - silikonieren

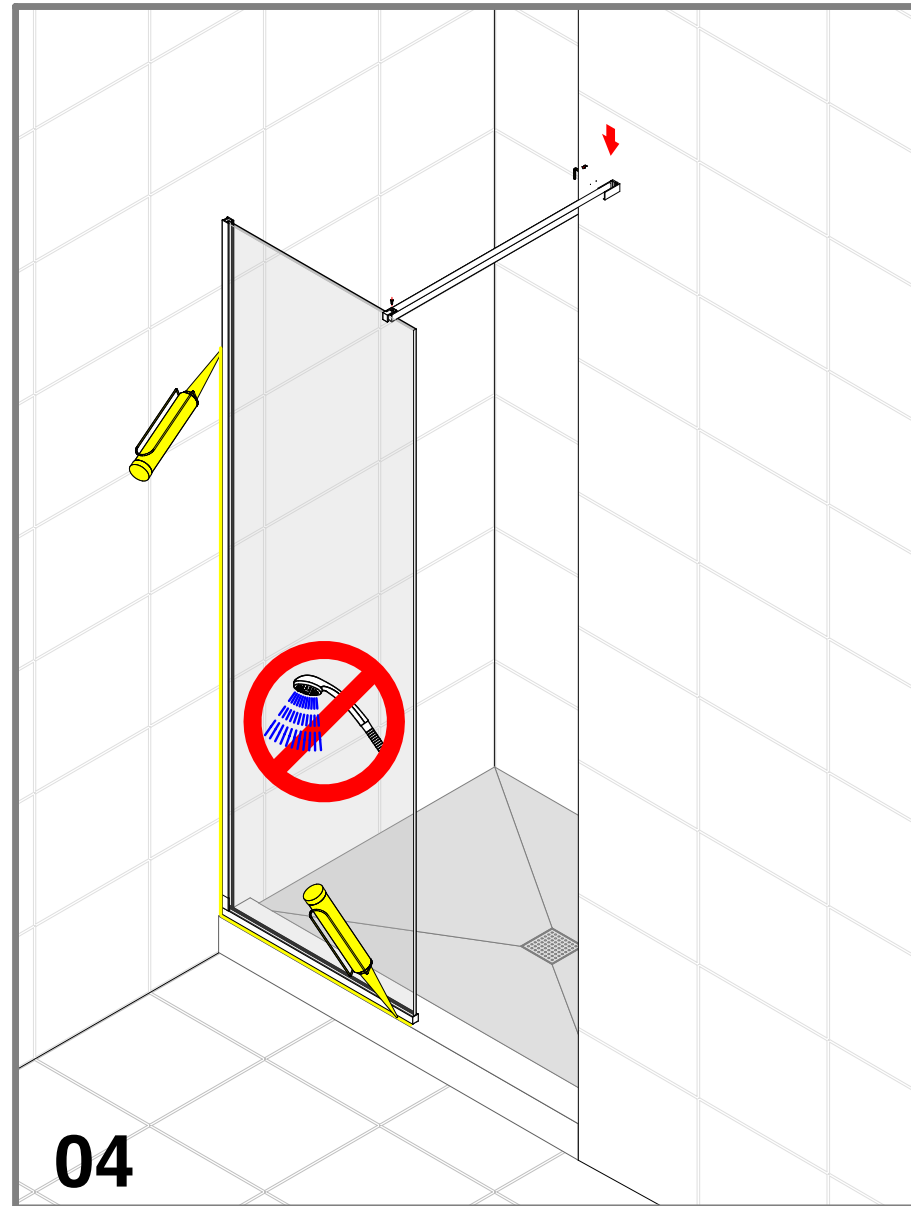

lama box parete vetro fisso
 lama shower enclosure corner sliding door
 lama Eck-Duschkabine mit Schiebetür

fasì di montaggio
 assembly steps
 Montage-Schritte

verifica di cantiere
 check on site
 vorbereitende Kontrollen

compensazione fuori piombo
 compensation of level differences
 Schrägen ausgleichen

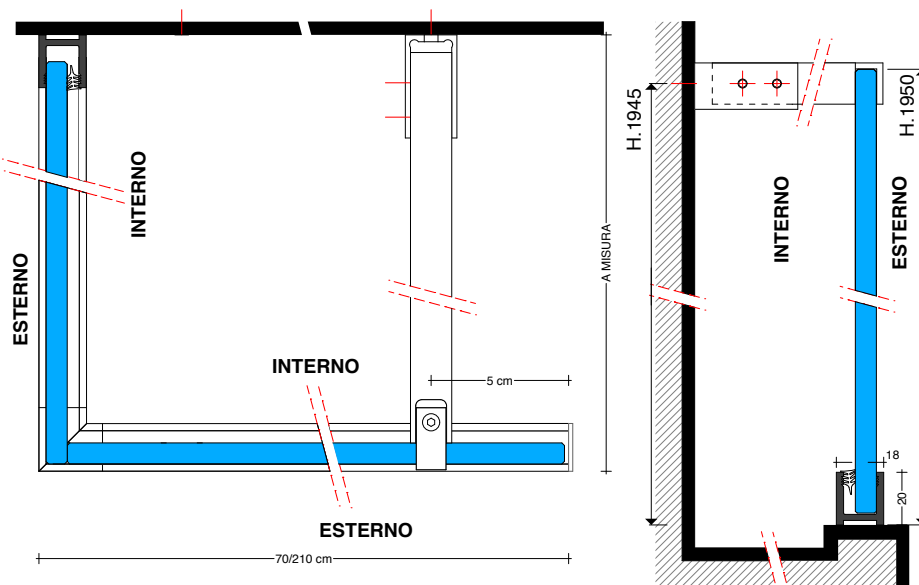
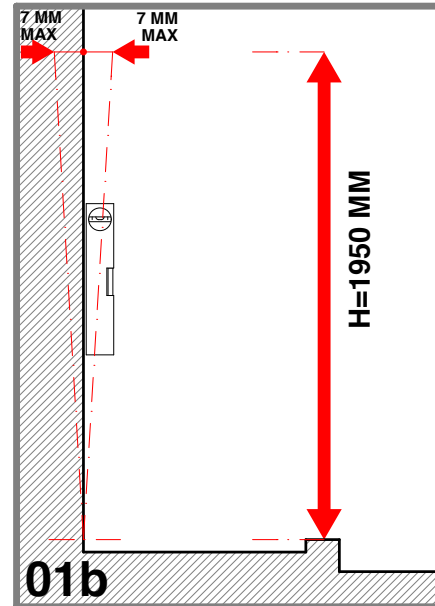
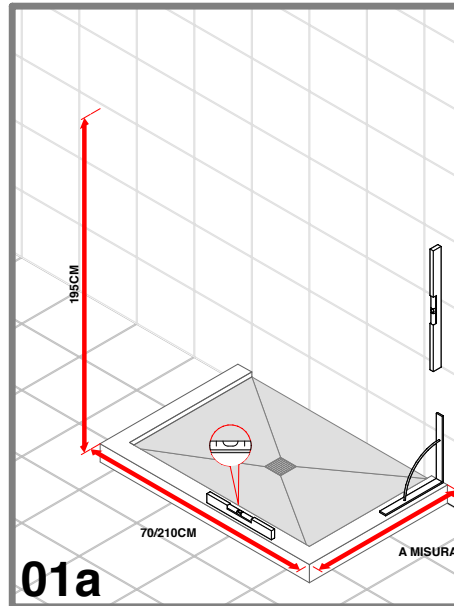
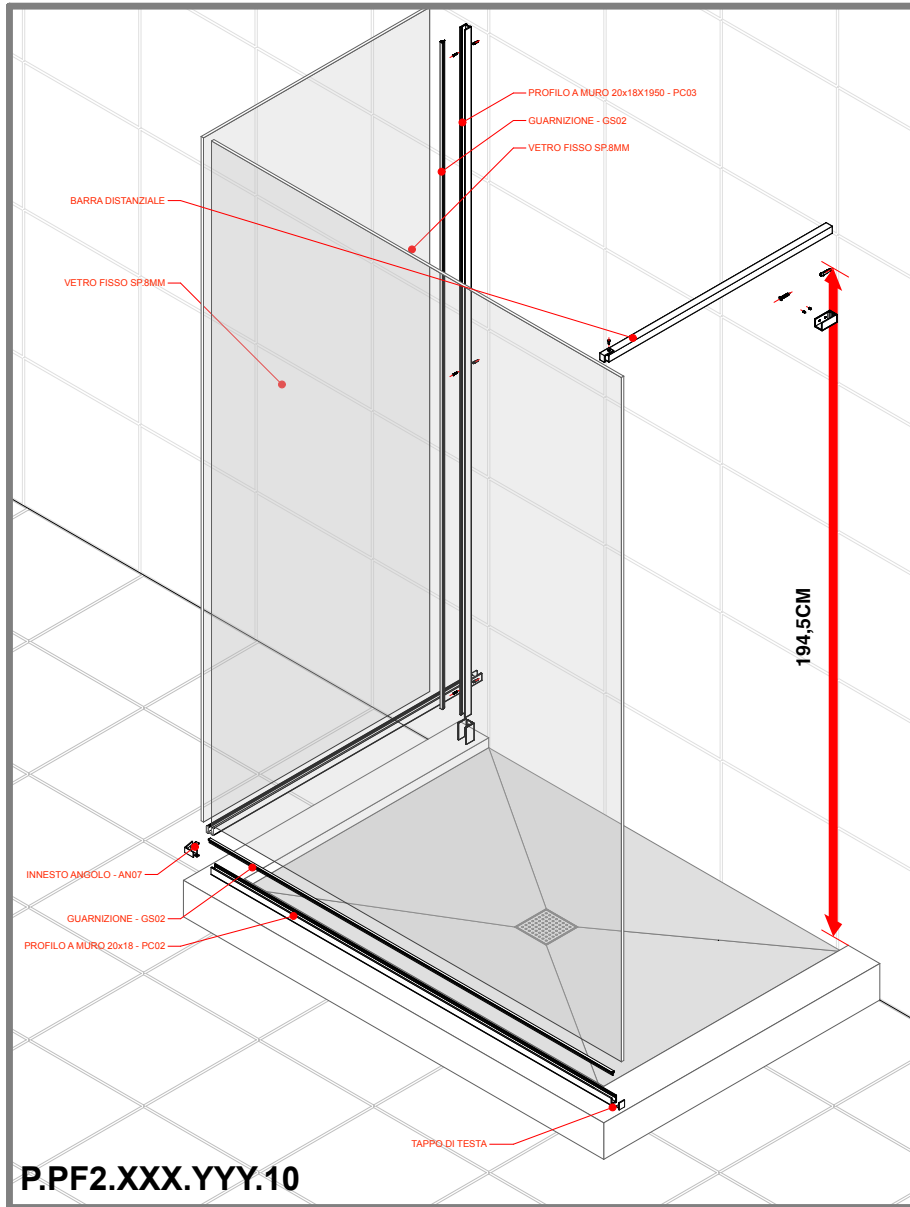

foratura pareti, montaggio vetro fisso e guarnizione
boring walls, assembly fixed glass panels and gaskets
Montage feststehende Glaswände und Dichtungen

posa e incollaggio con silicone del telaio inferiore
positioning and fixing of the lower profiles with silicon
Positionieren und Aufkleben der Bodenprofile mit Silikon

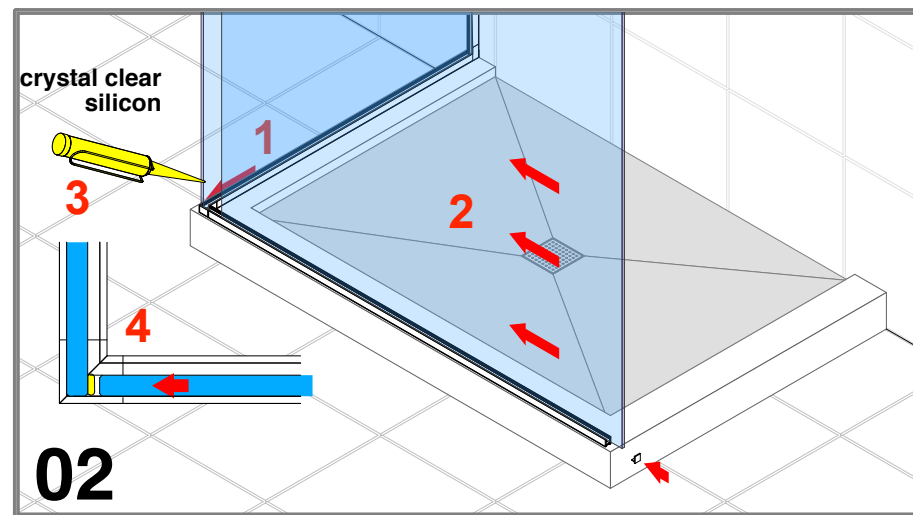
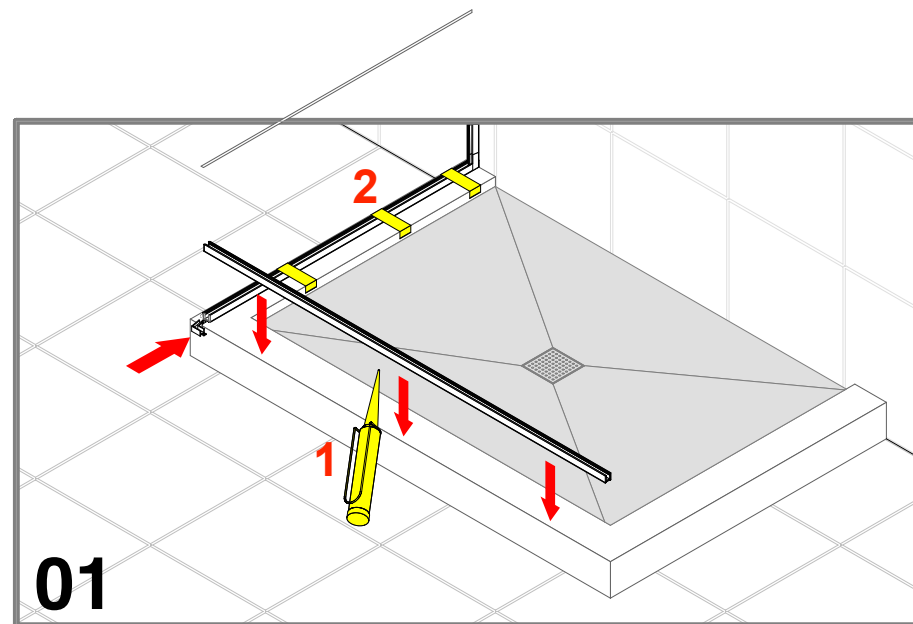
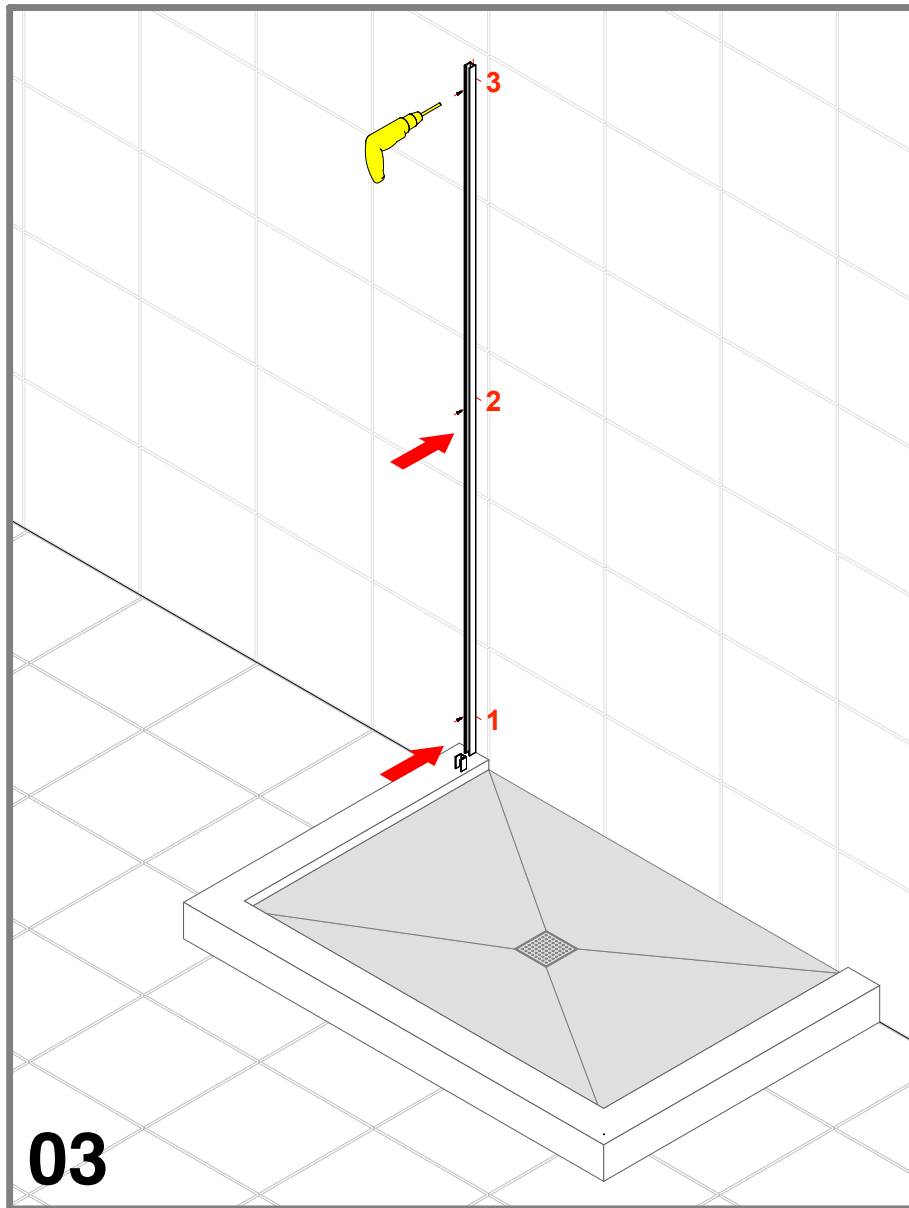

montaggio barra
assembly bar
Montage bar

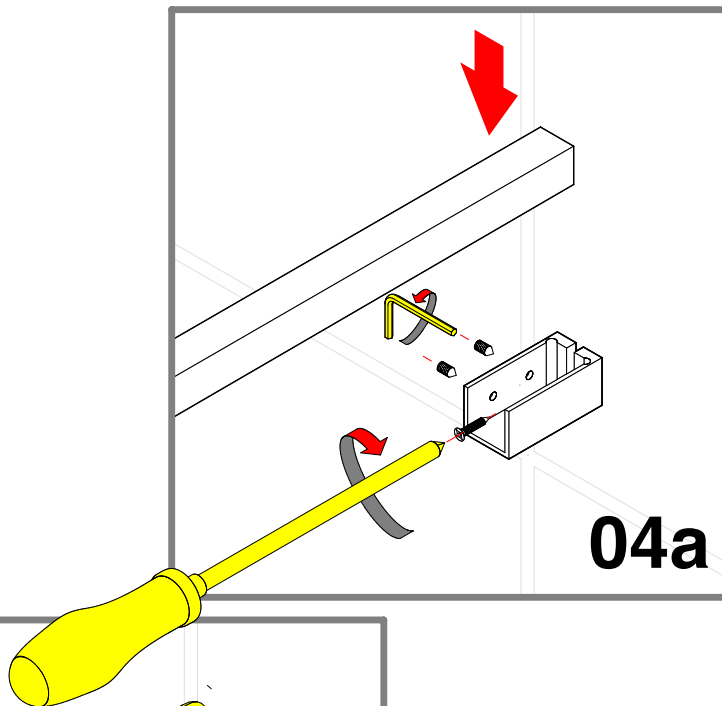

04a

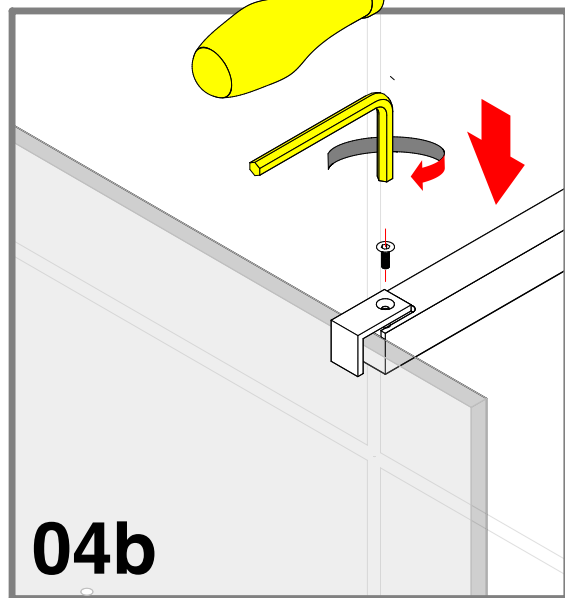

04b

montaggio vetro fisso e barra - siliconatura
assembly of the fixed glasses and bar - silicone
Montage der Tür - befestigen - silikonieren

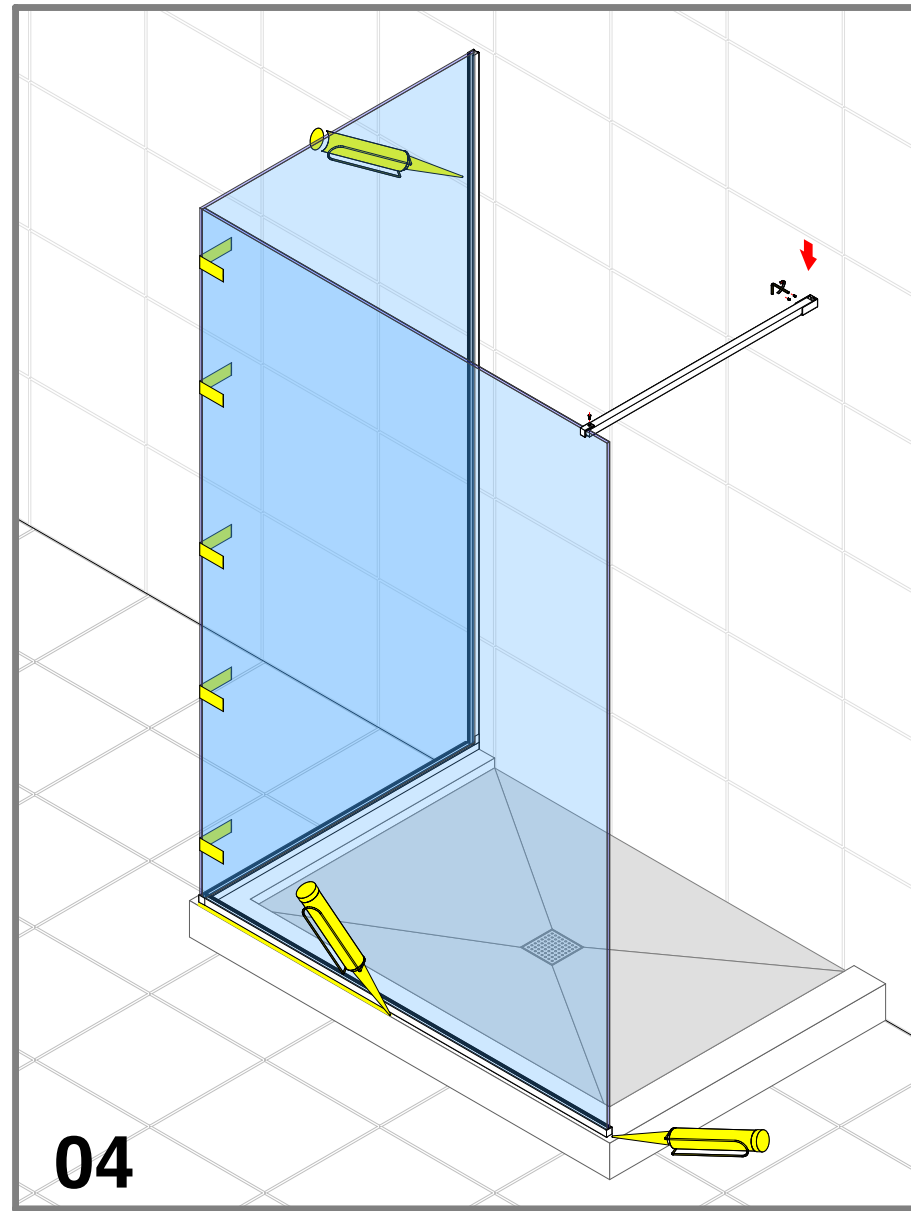

04

lama box parete vetro fisso
 lama shower enclosure corner sliding door
 lama Eck-Duschkabine mit Schiebetür

fasi di montaggio
 assembly steps
 Montage-Schritte

verifica di cantiere
 check on site
 vorbereitende Kontrollen

compensazione fuori piombo
 compensation of level differences
 Schrägen ausgleichen

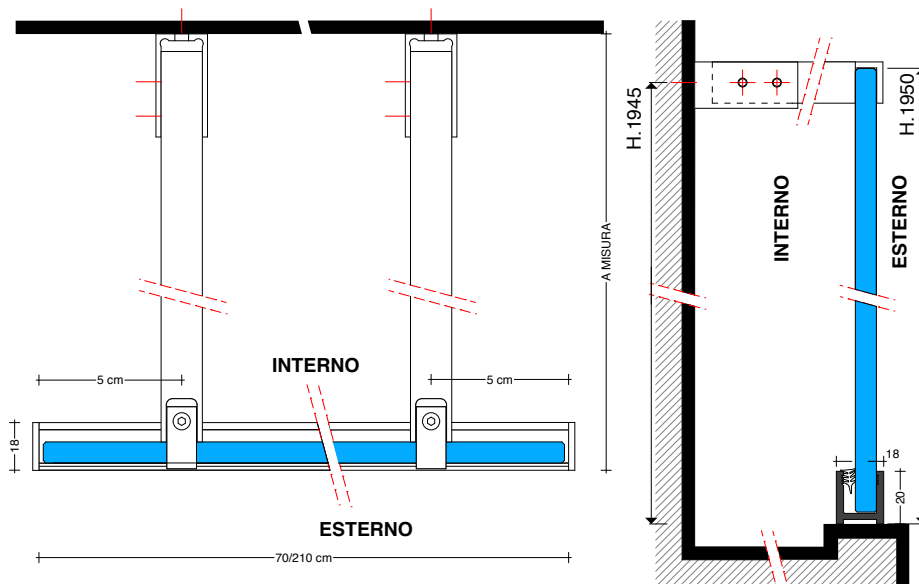
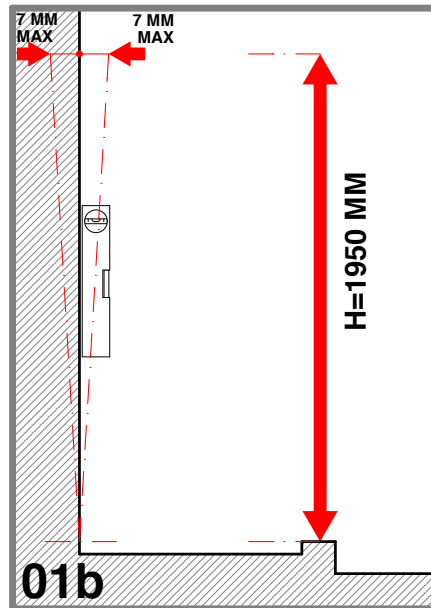
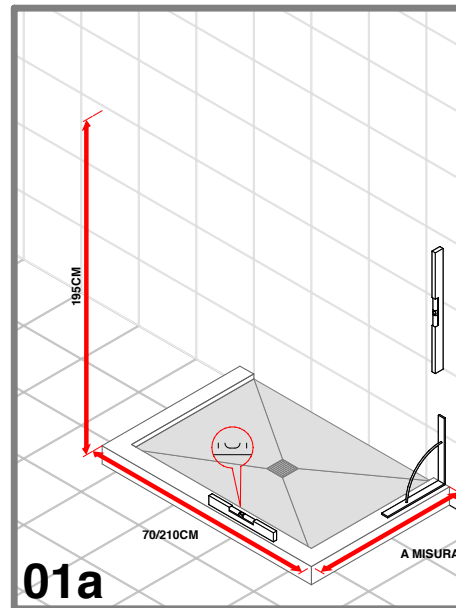
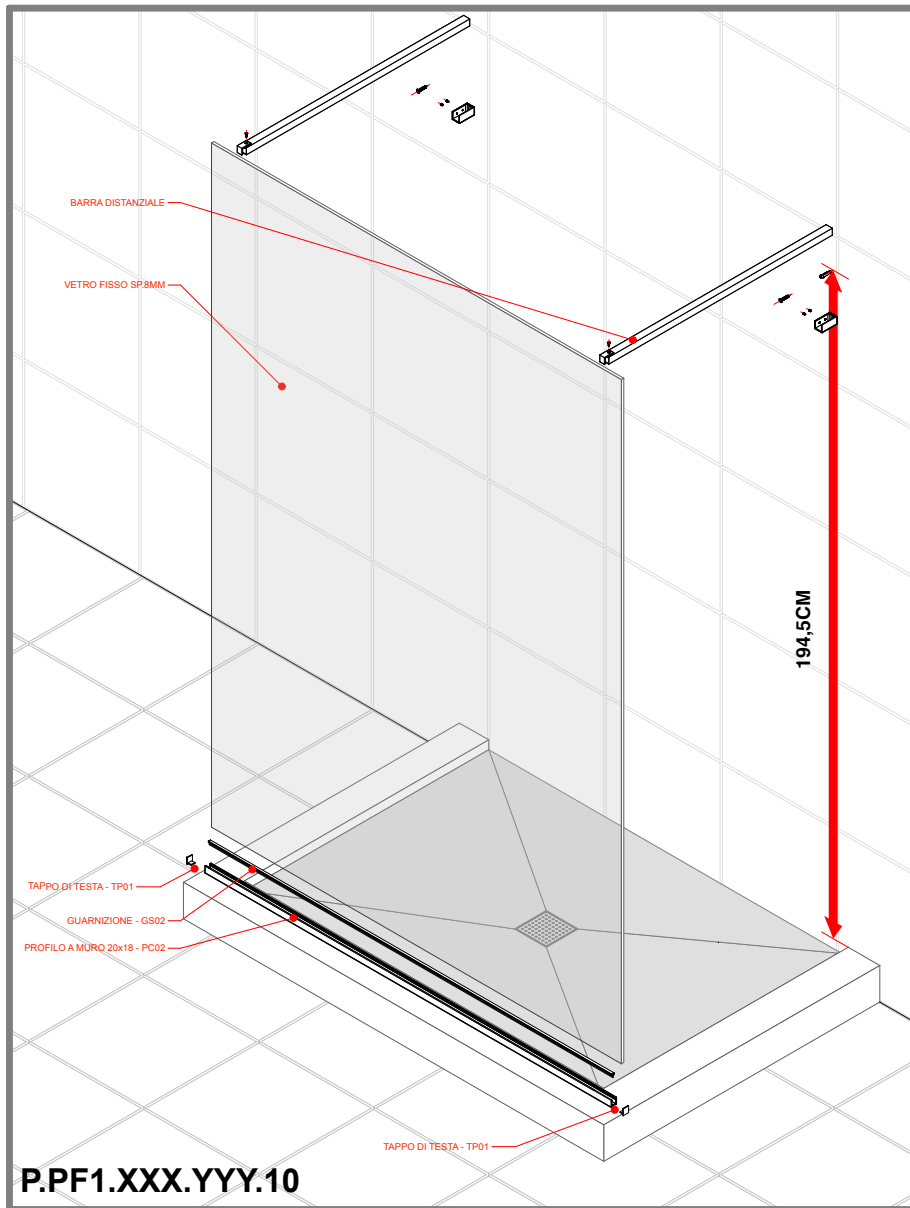

posa e incollaggio con silicone del telaio inferiore
positioning and fixing of the lower profiles with silicon
Positionieren und Aufkleben der Bodenprofile mit Silikon

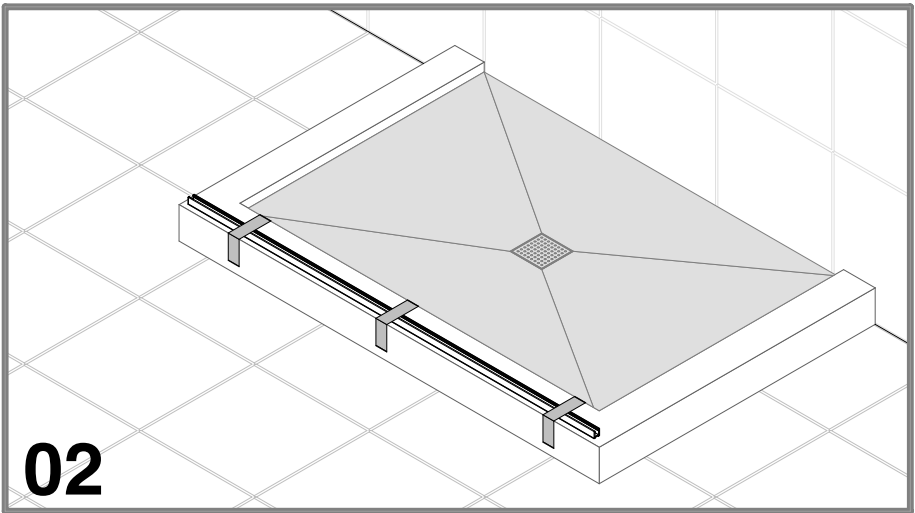
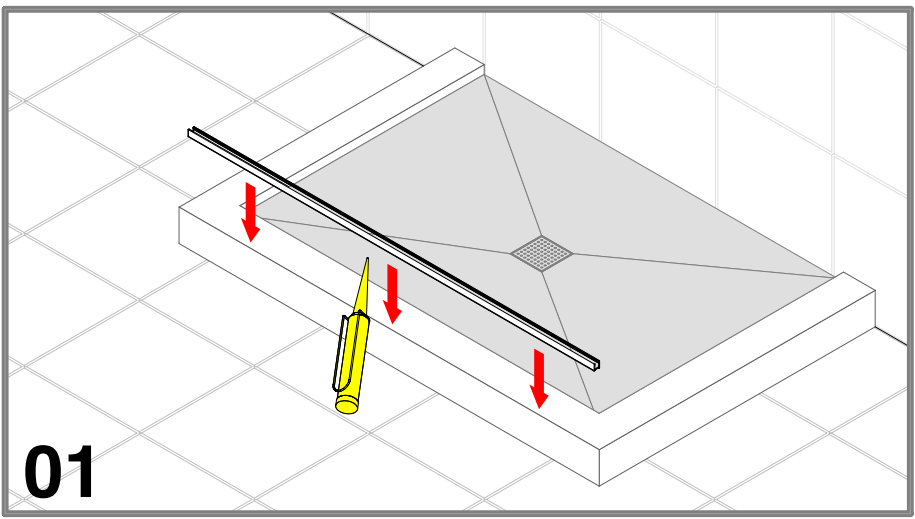

foratura pareti, montaggio vetro fisso e guarnizione
boring walls, assembly fixed glass panels and gaskets
Montage feststehende Glaswände und Dichtungen

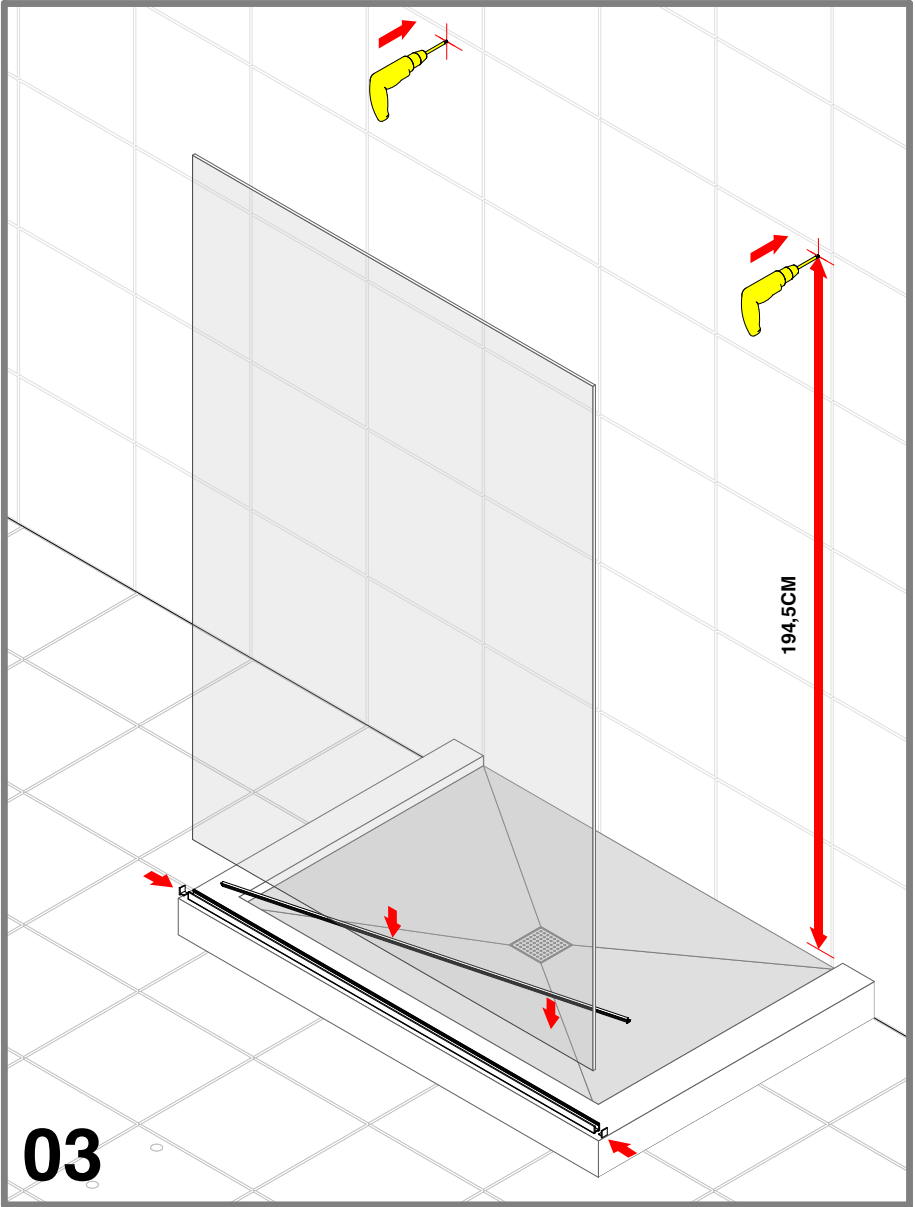

montaggio barra
assembly bar
Montage bar

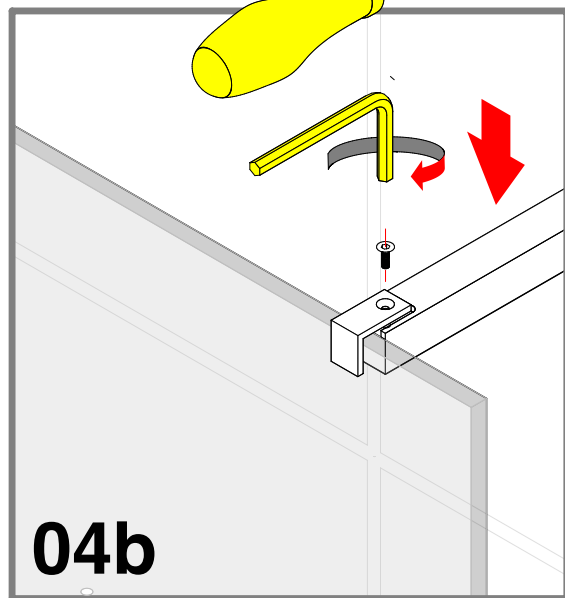
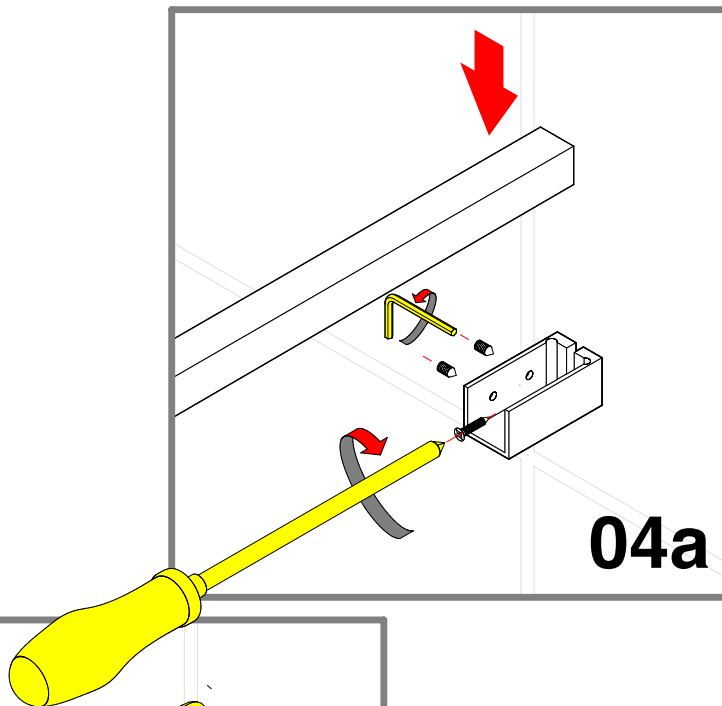

montaggio vetro fisso e barra - siliconatura
assembly of the fixed glasses and bar - siliconing
Montage der Tür - befestigen - silikonieren

