

# SPIN \_ PBNA assembly

nicchia / niche

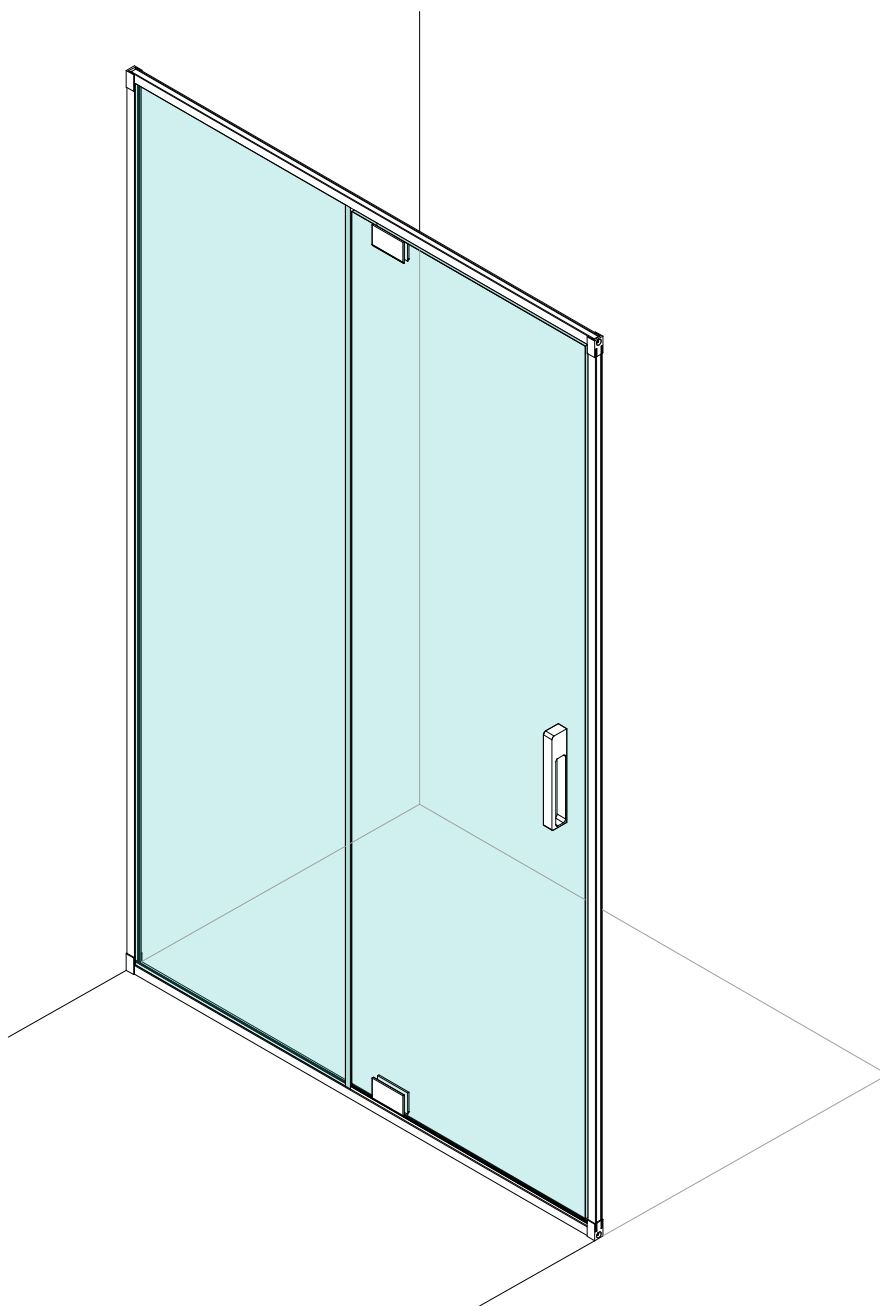

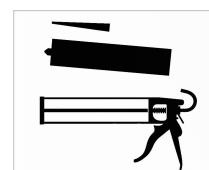
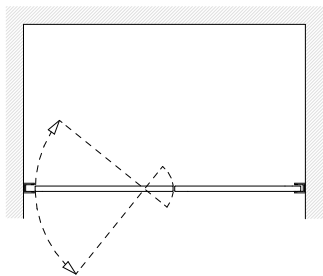
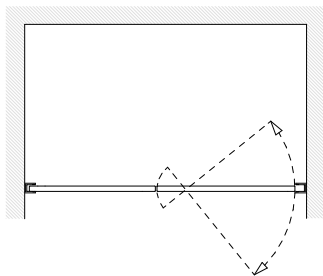
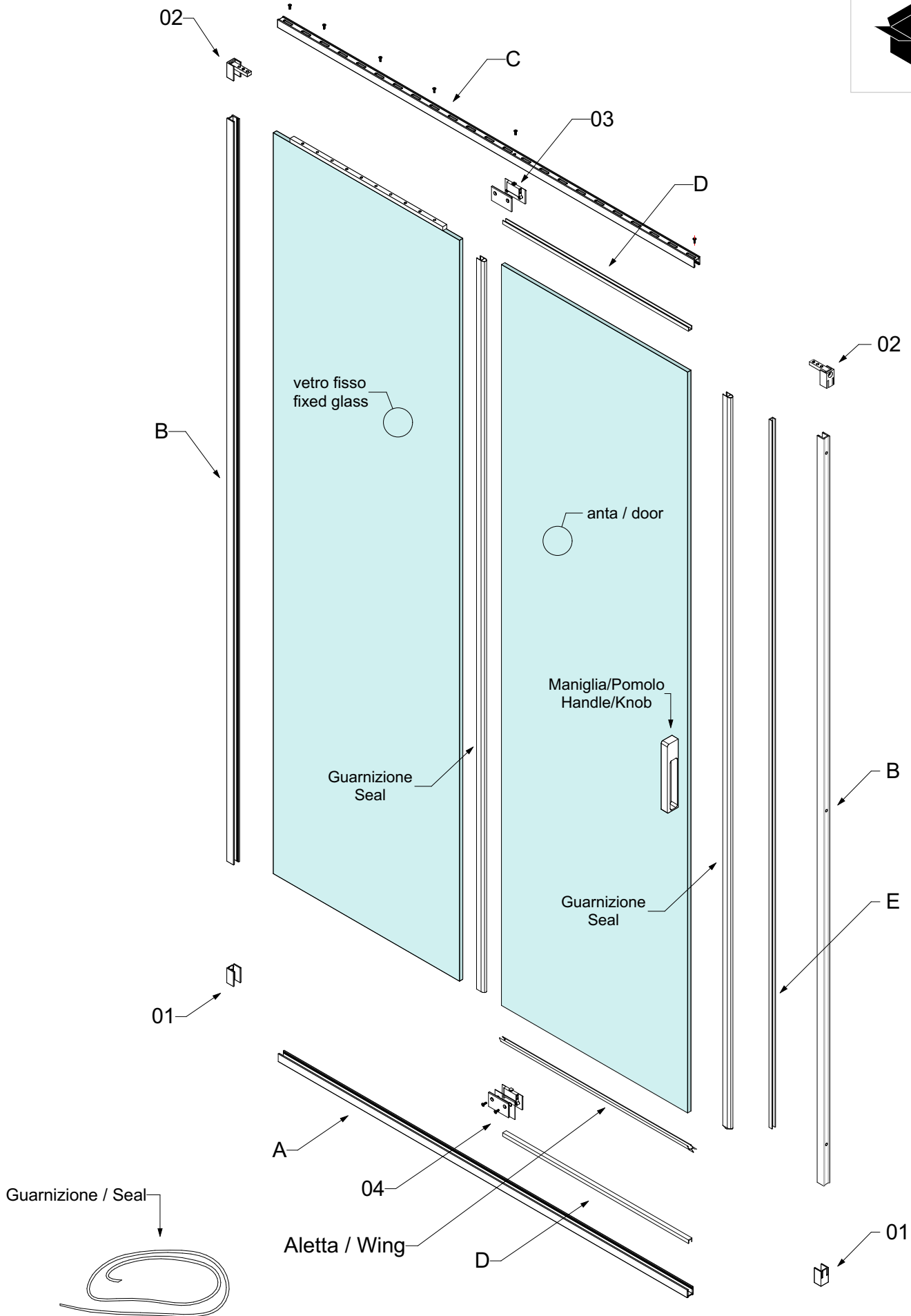
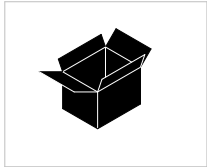

**PROFILI / PROFILE**

**A** BARRA INFERIORE

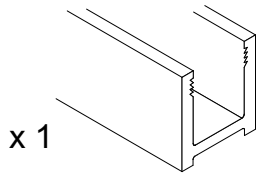

**B** VERT

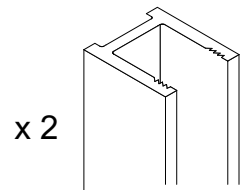

**C** BARRA SUPERIORE

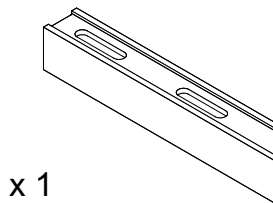

**D** COPRICAVA

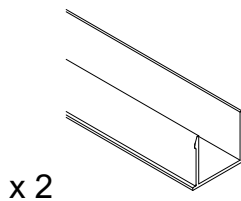

**E** COPRICAVA VERT

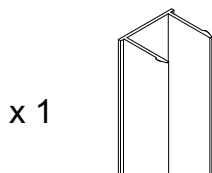

**INNESTI / JOINT**

**01** IN11

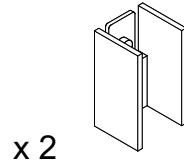

**02** IN11+IN09

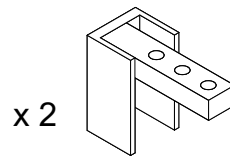

**03** CERNIERA SUPERIORE

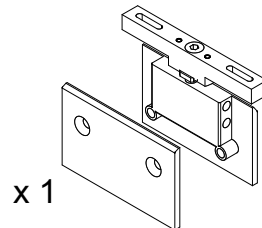

**04** CERNIERA INFERIORE

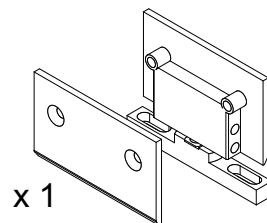

**GUARNIZIONI / SEAL**

PALLONCINO /  
BALOON SEAL  
GV04

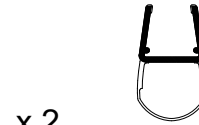

ALETTA / WING SEAL

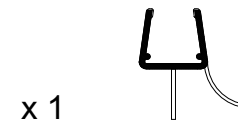

GUARNIZIONE PROFILO /  
PROFILE SEAL  
GS01



GUARNIZIONE CERNIERA /  
PIVOT SEAL

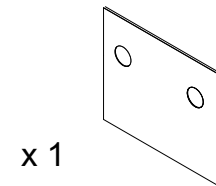

VITI FISSAGGIO  
FIXING SCREW

x 12



MANIGLIA-POMOLO  
HANDLE-KNOB

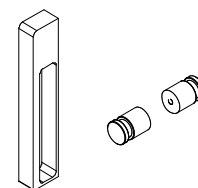

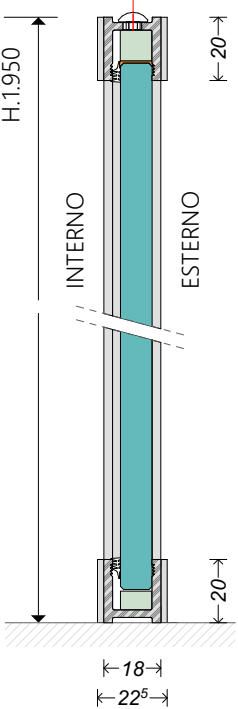
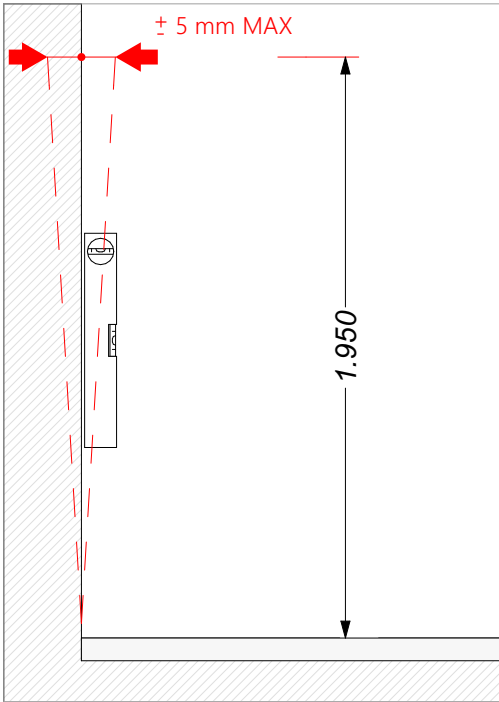
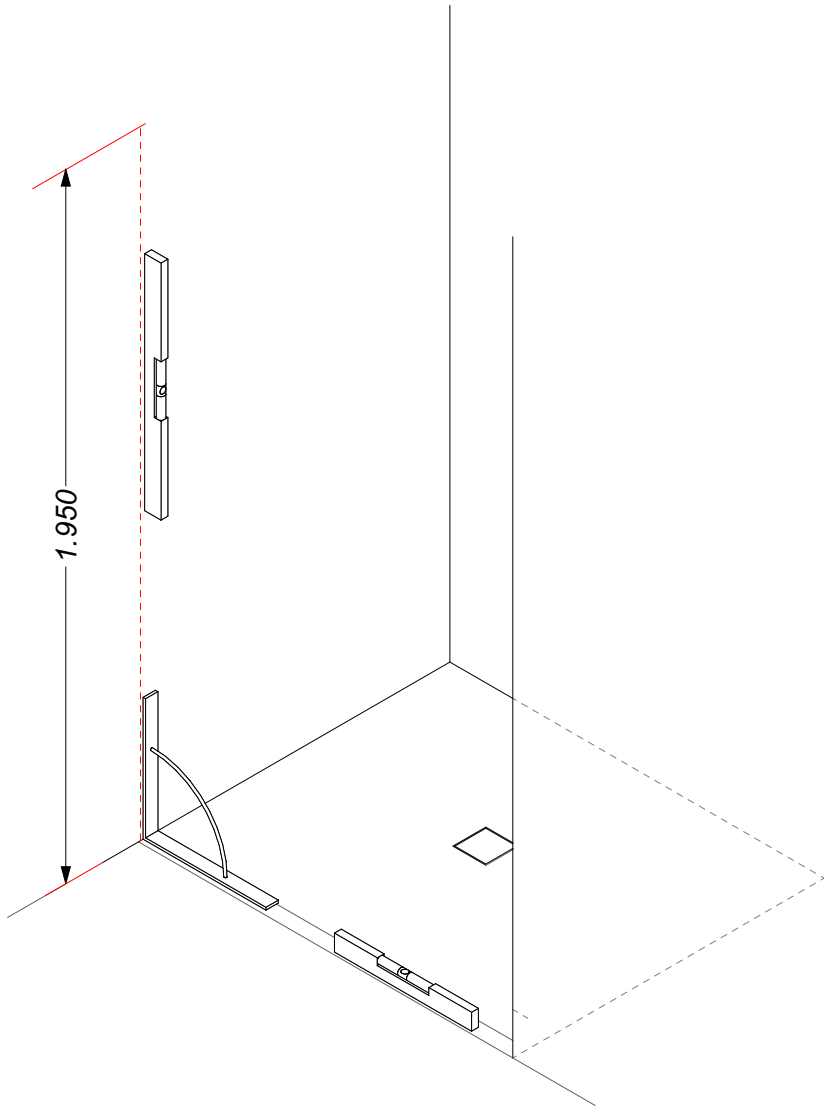

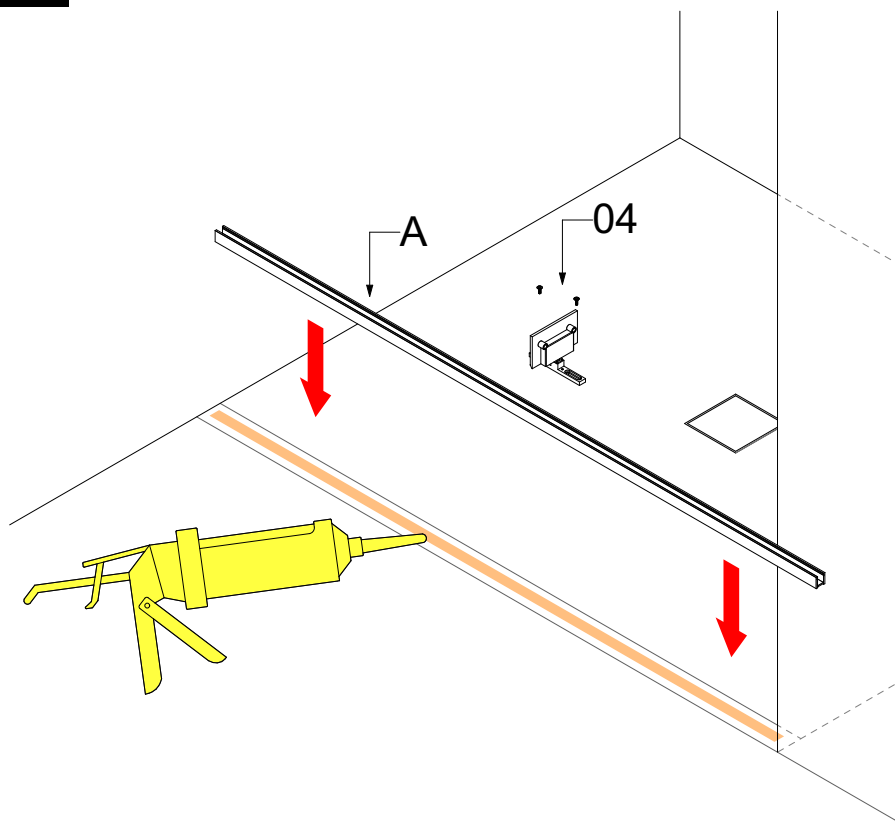

**⚠ ATTENTION**

Individuare il foro di montaggio del perno anta per posizionare correttamente il profilo a terra.

Find the hole for the door's hinge installation, in order to correctly locate the floor profile.

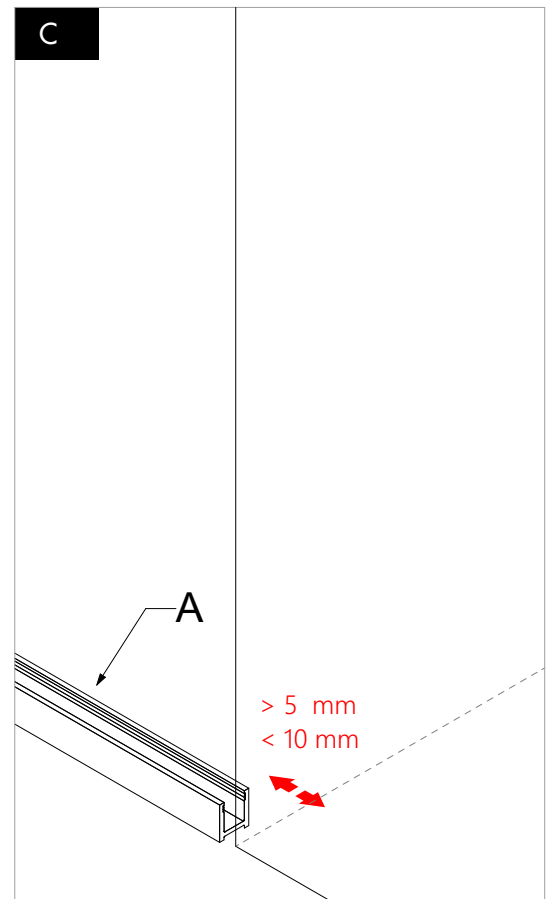
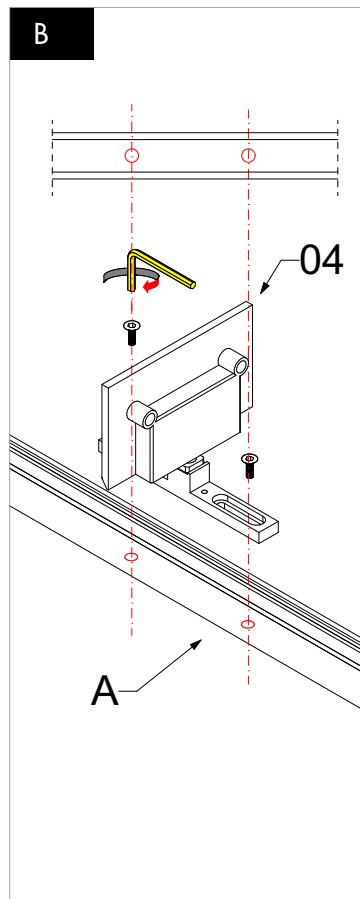
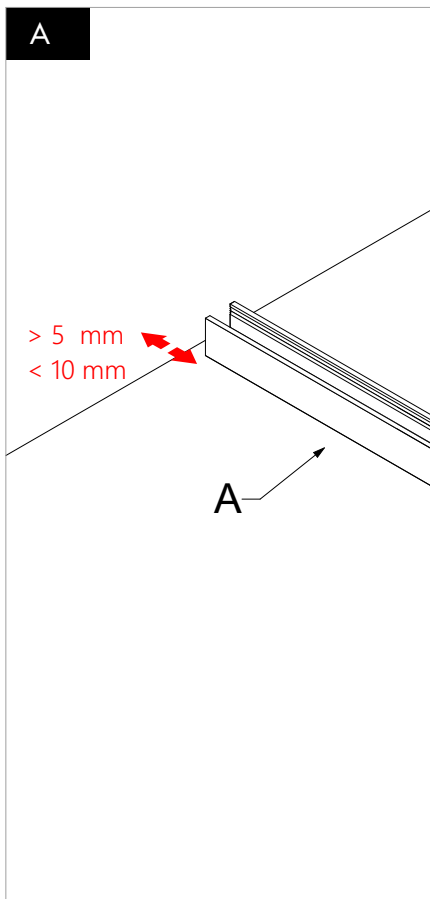



ATTENTION

Attenzione centratura tra innesti e profili.  
 - Pay attention to the grafts and profiles' centration.

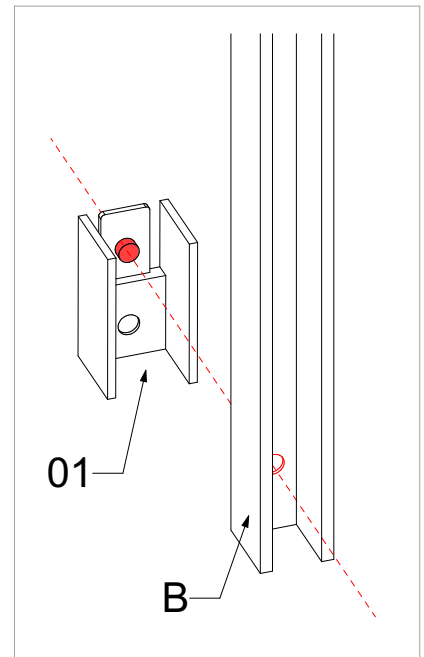
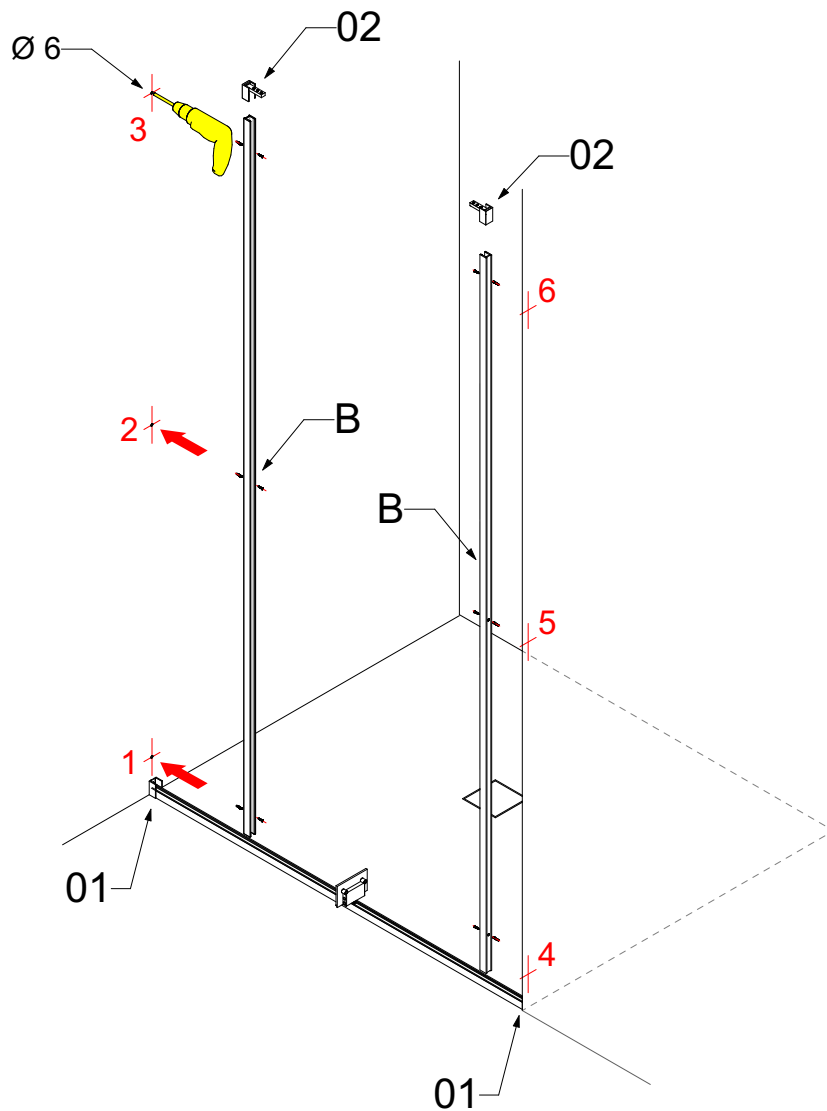

Sinistra / Left

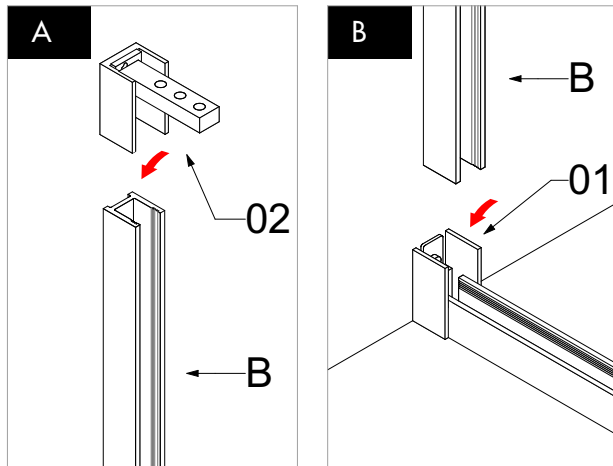

Destra / Right

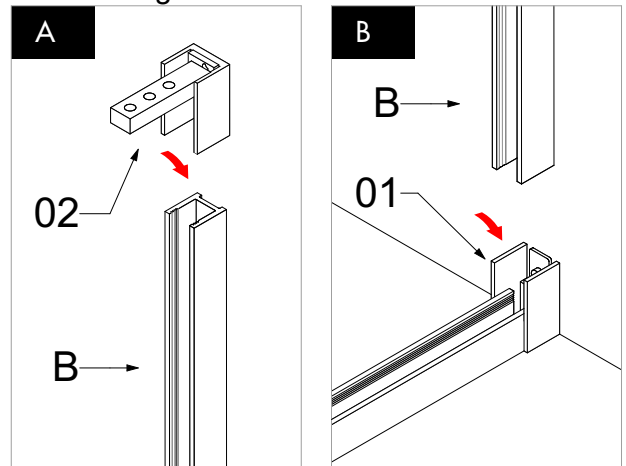



## ATTENTION

Attenzione silliconatura interna  
innesti.

-  
Put sylicone on the inner side  
of the grafts.

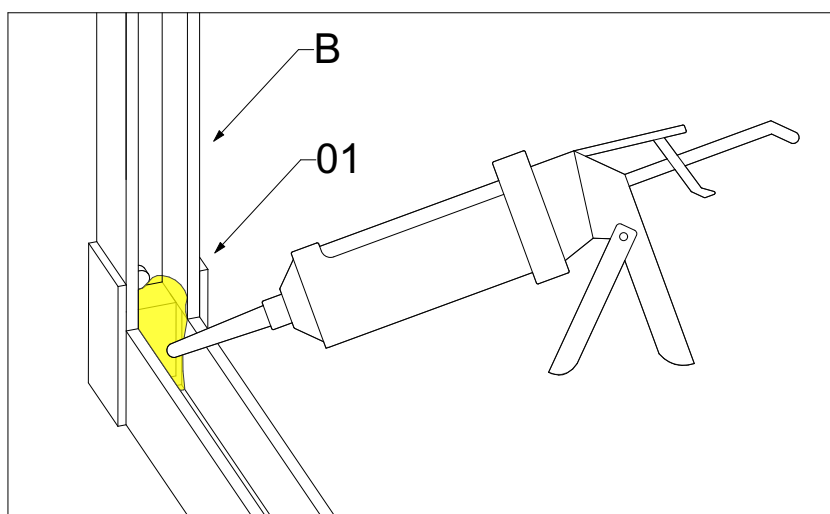
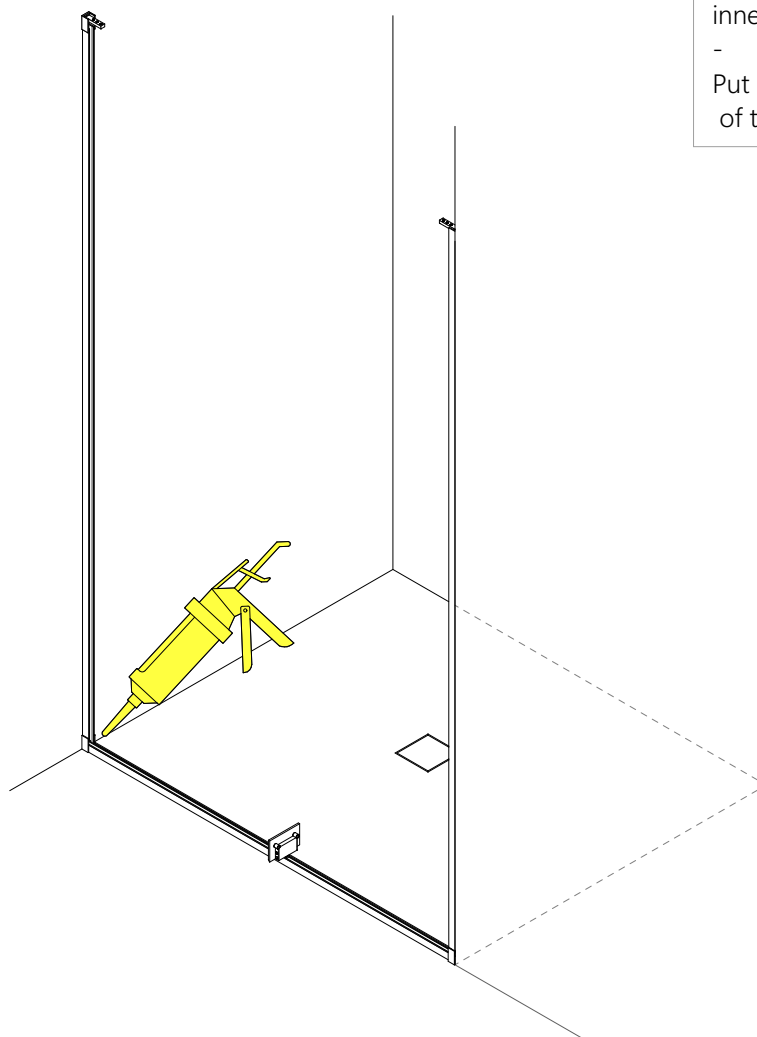

/ 04

INSTALLAZIONE VETRI E BARRA SUPERIORE  
GLASS AND UPPER BAR INSTALLATION

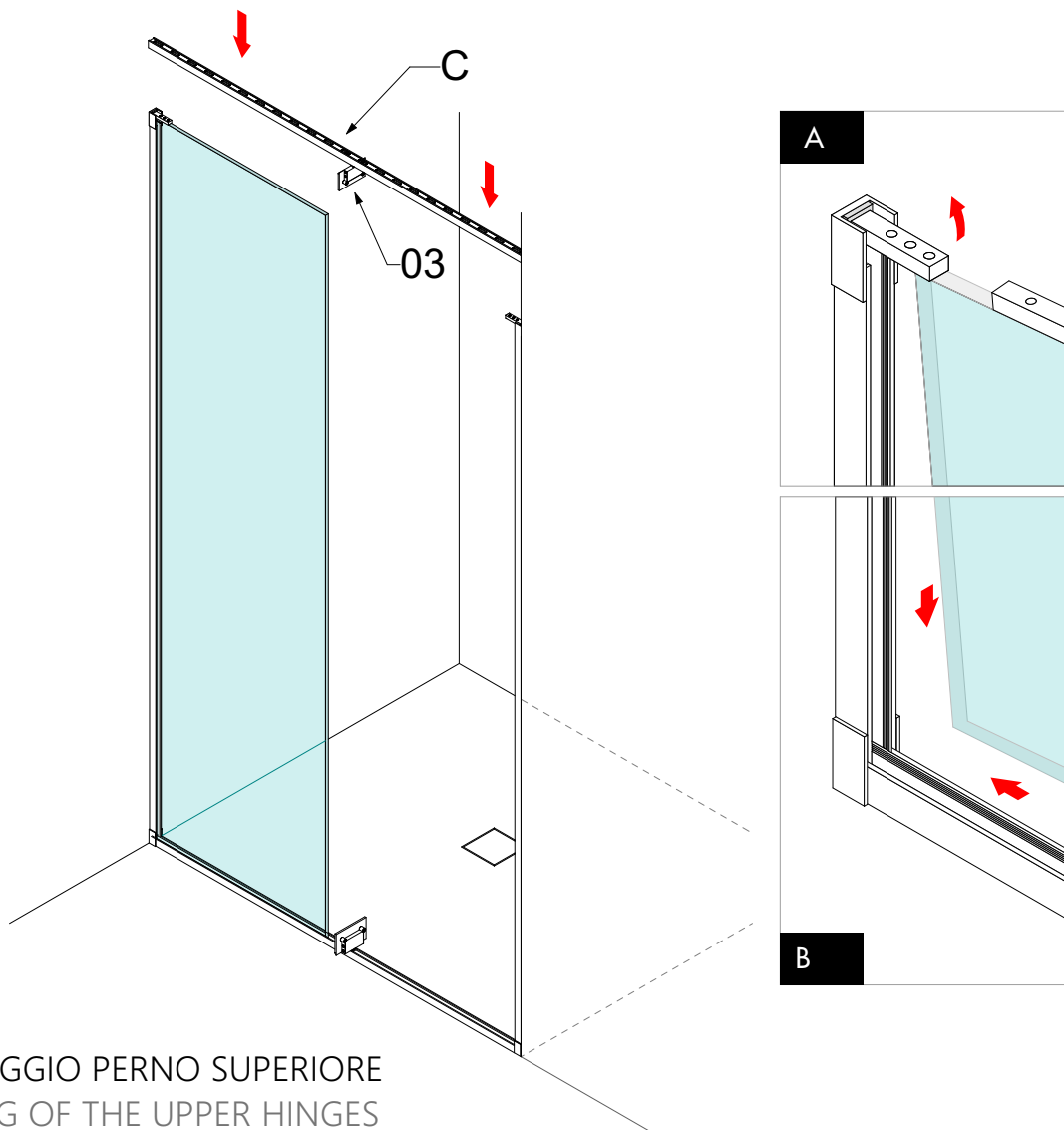

04 a

FISSAGGIO PERNO SUPERIORE  
FIXING OF THE UPPER HINGES

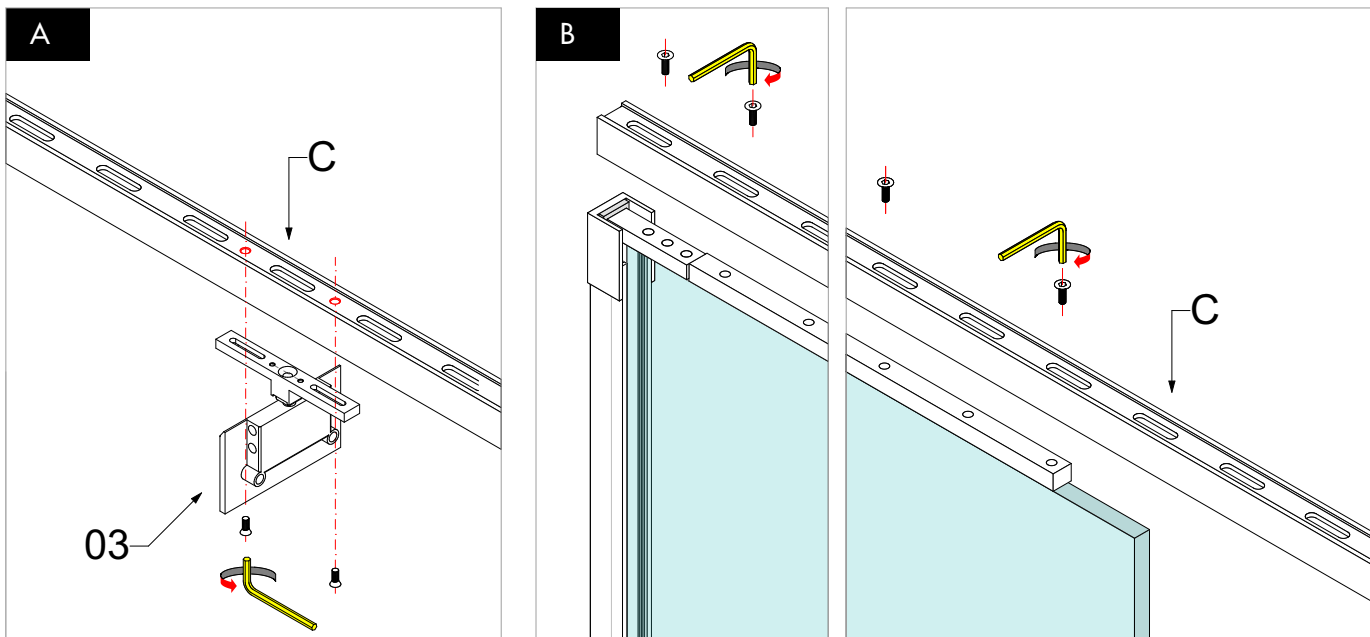



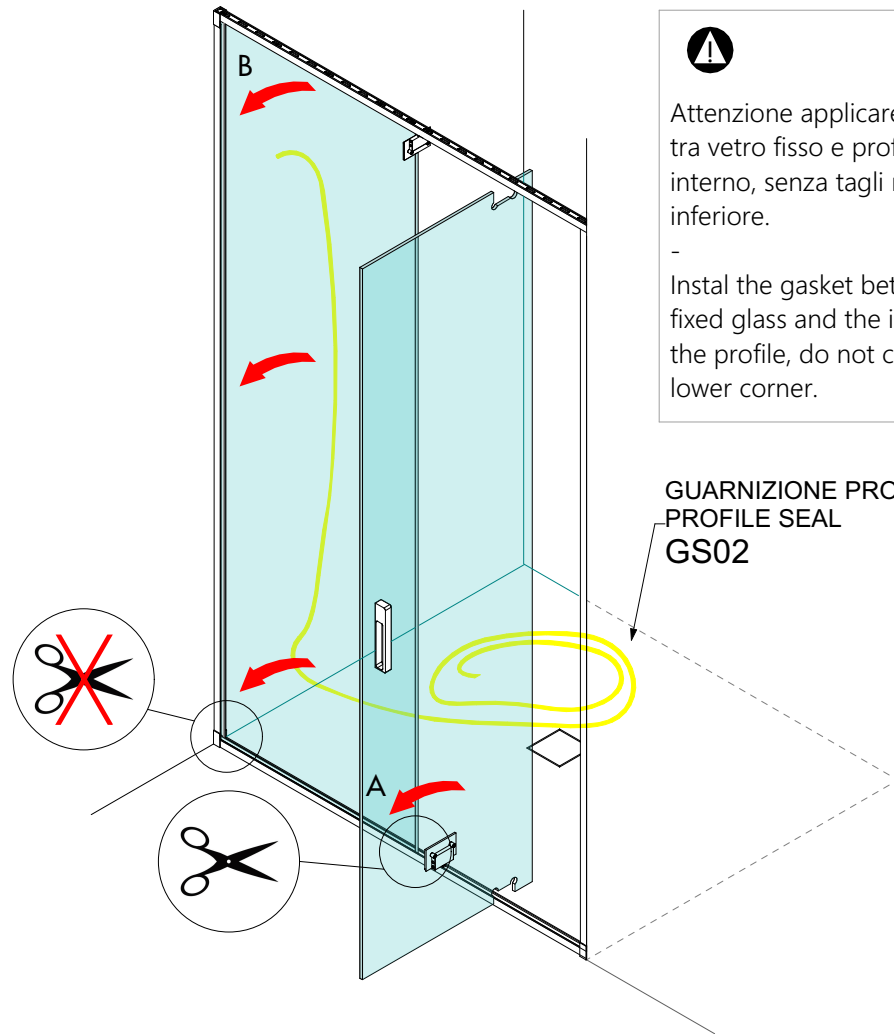
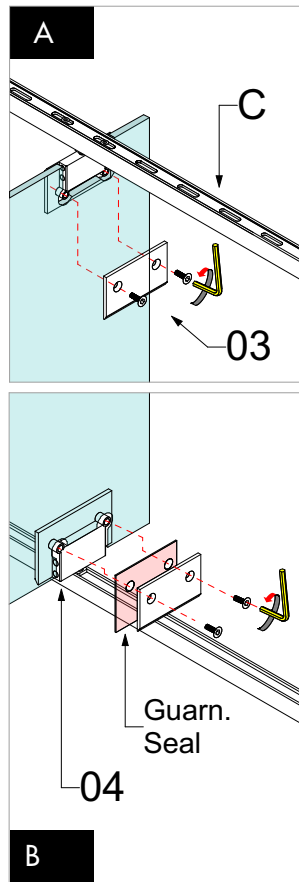

Attenzione applicare guarnizione tra vetro fisso e profilo sul lato interno, senza tagli nell'angolo inferiore.

- Install the gasket between the fixed glass and the inner side of the profile, do not cut on the lower corner.

Vista dall'interno / Inside view

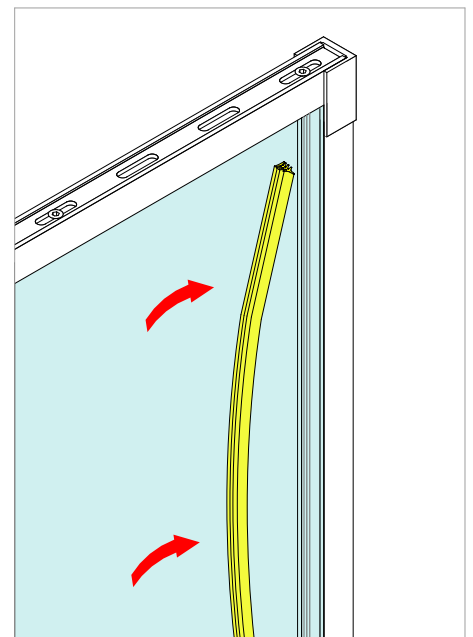
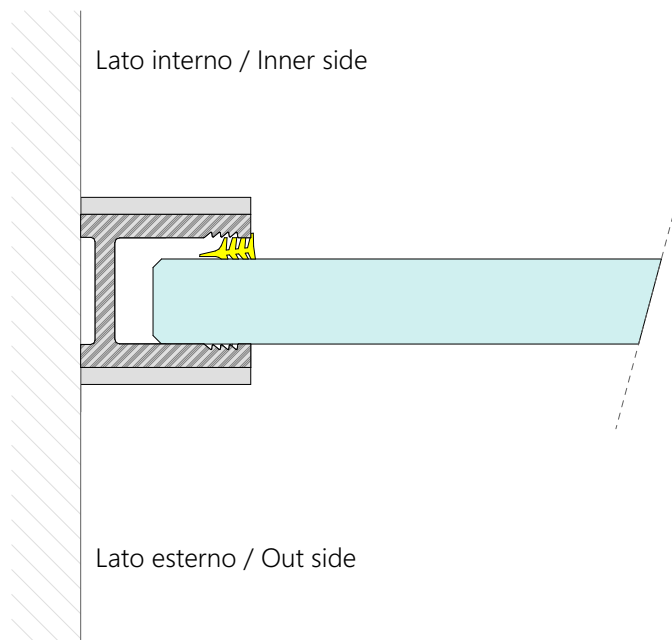



Silicone neutro non acetico  
antimuffa  
-  
Neutral acetic anti-mold silicone

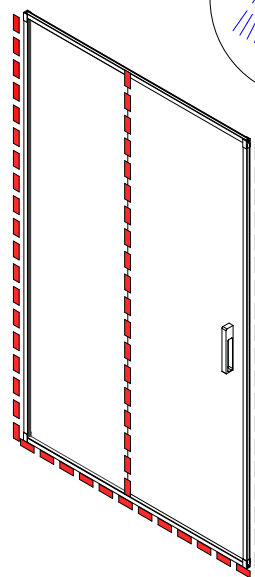
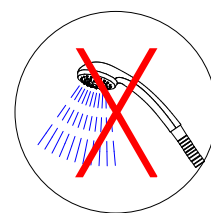
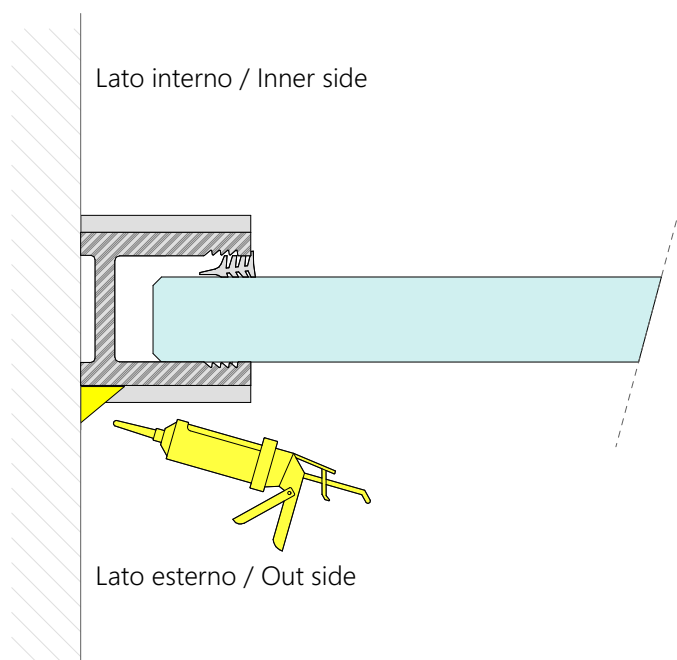
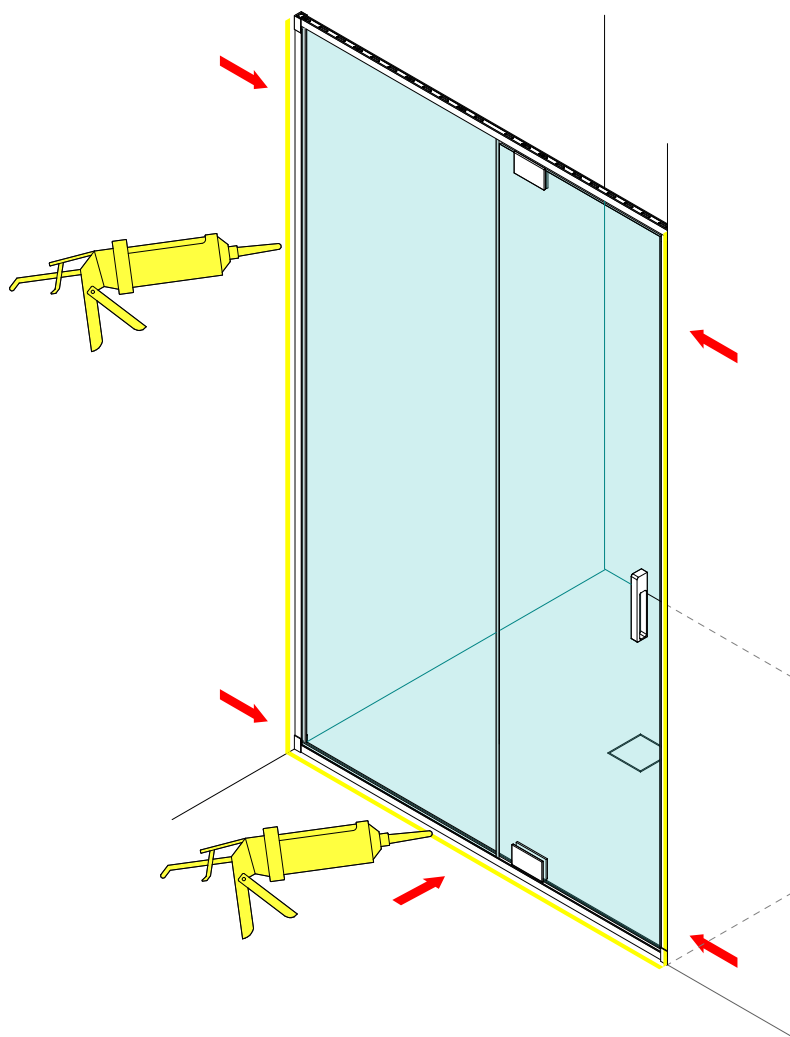

APPLICAZIONE GUARNIZIONI BATTENTE + STOP SUPERIORE  
INSTALLATION OF THE HINGED GASKET + UPPER LOCK

  
Silicone neutro non acetico antimuffa  
-  
Neutral acetic anti-mold silicone

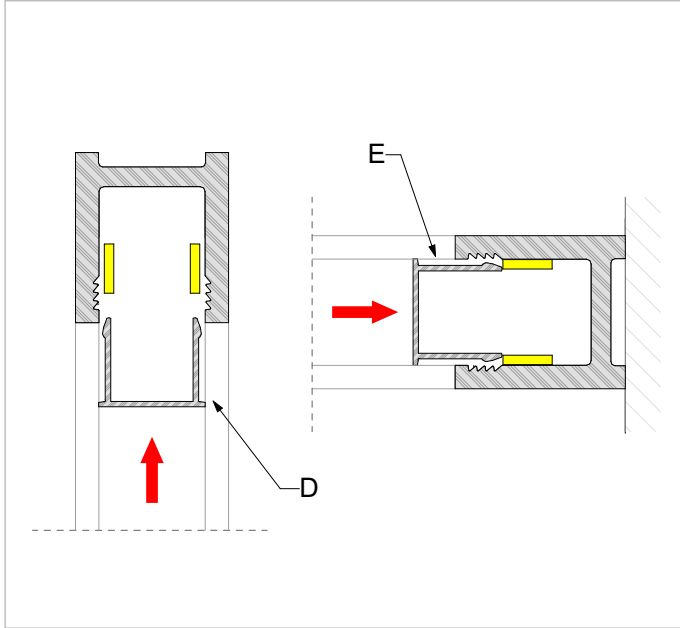
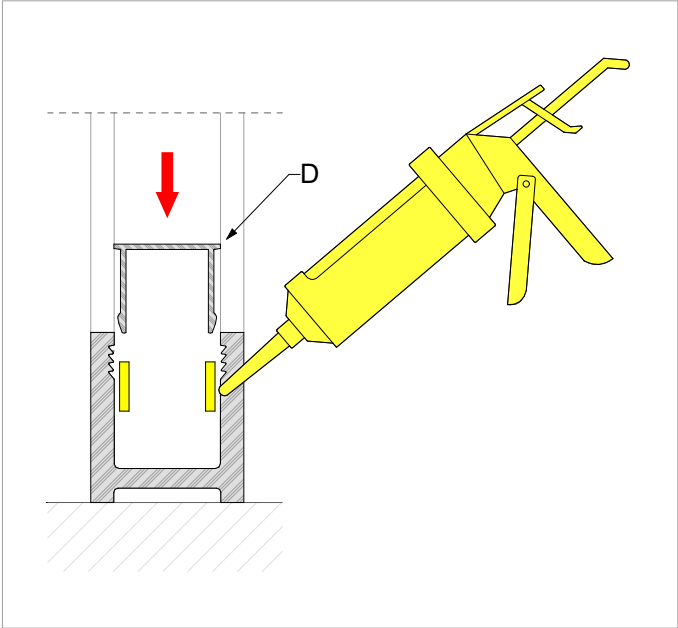
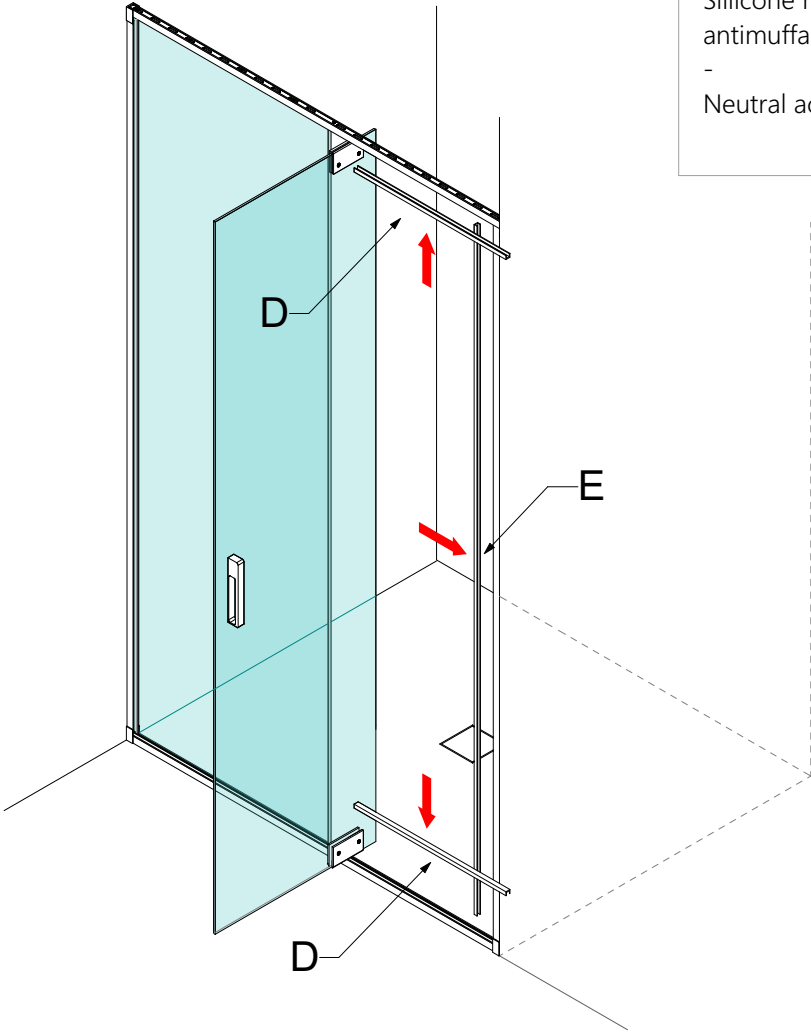

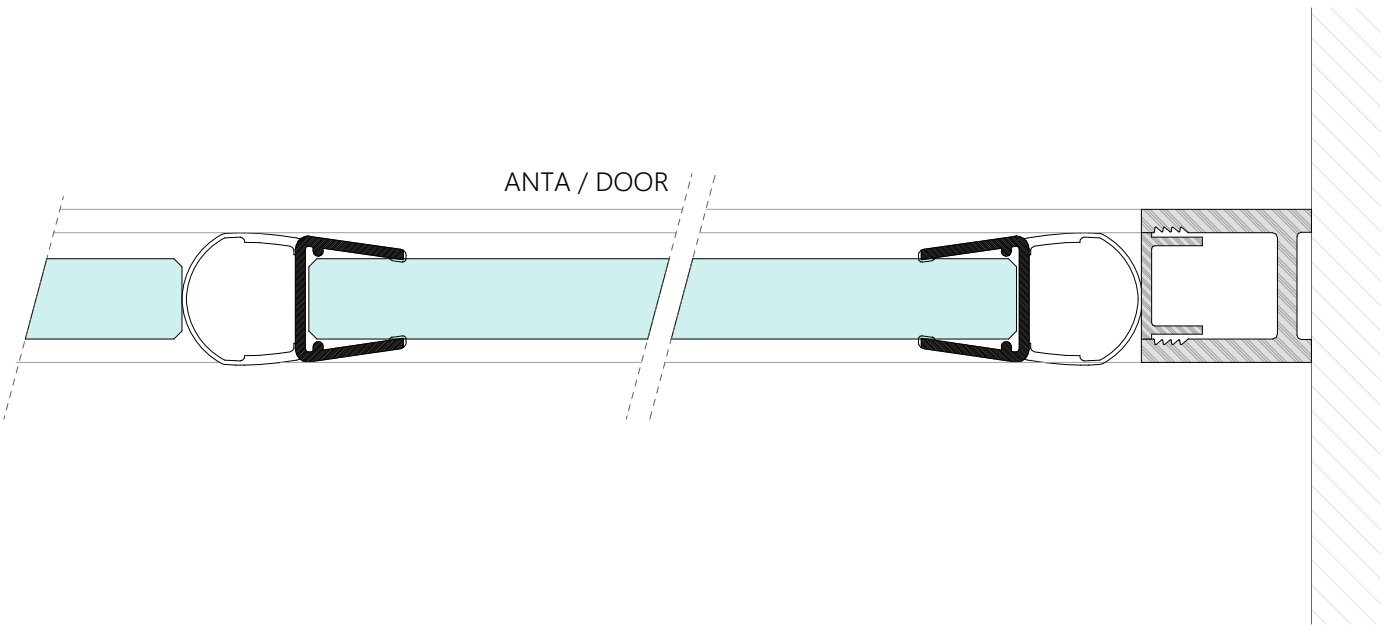
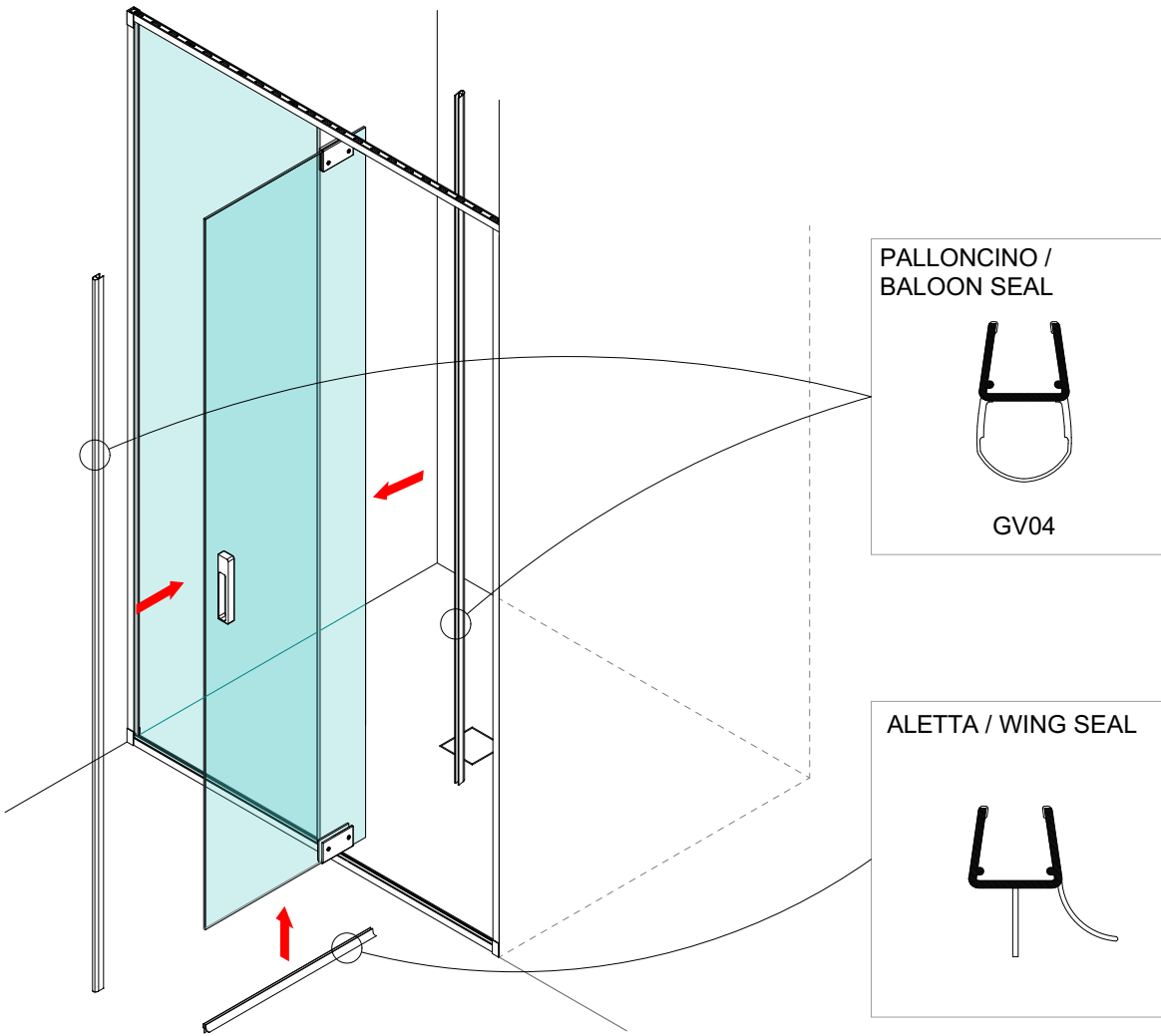

# SPIN \_ PBAA assembly

angolo / corner

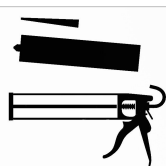
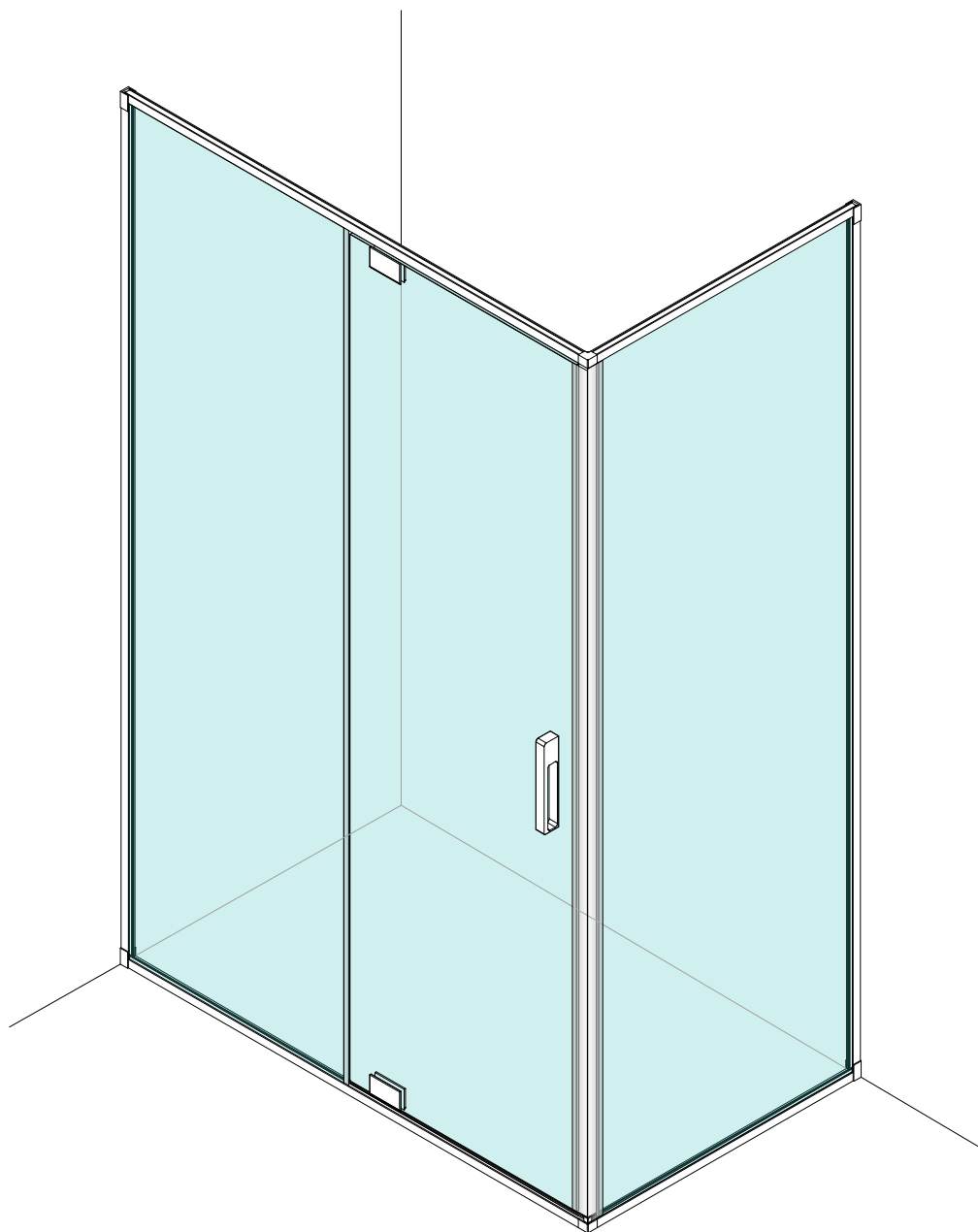
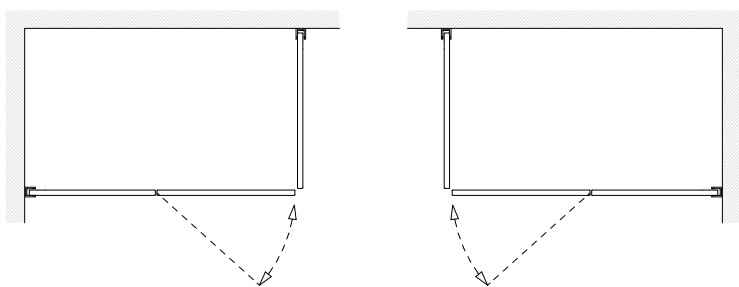

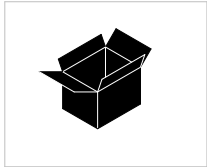

02

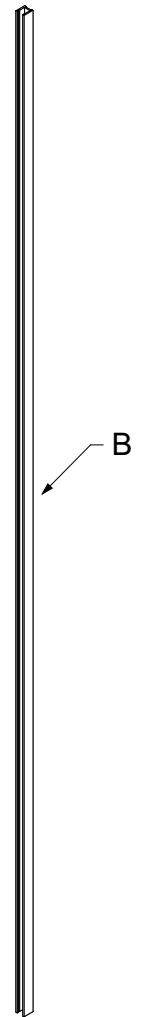
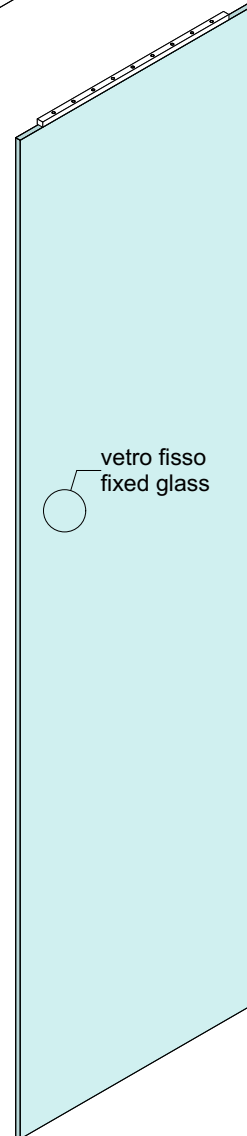
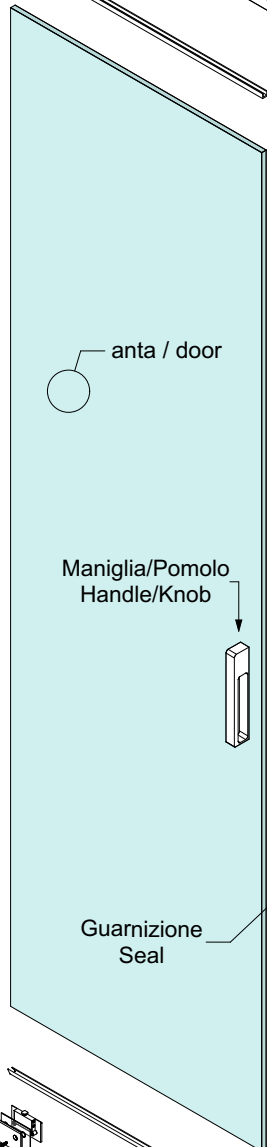
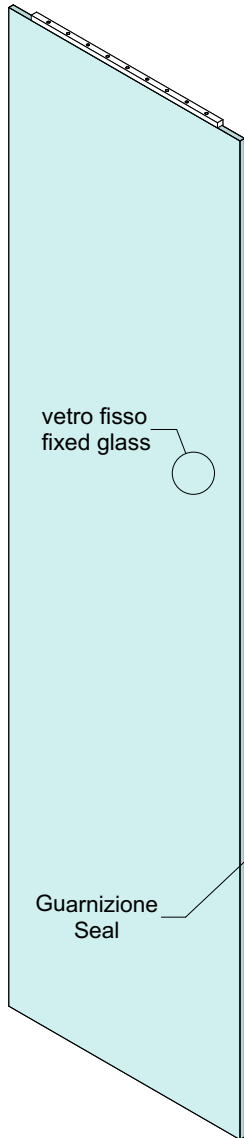
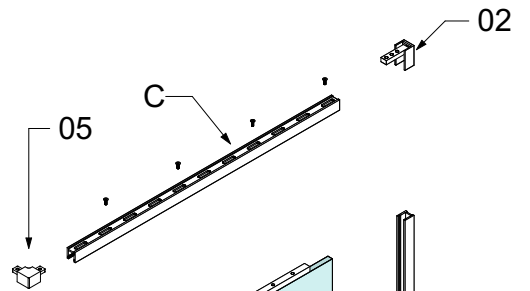
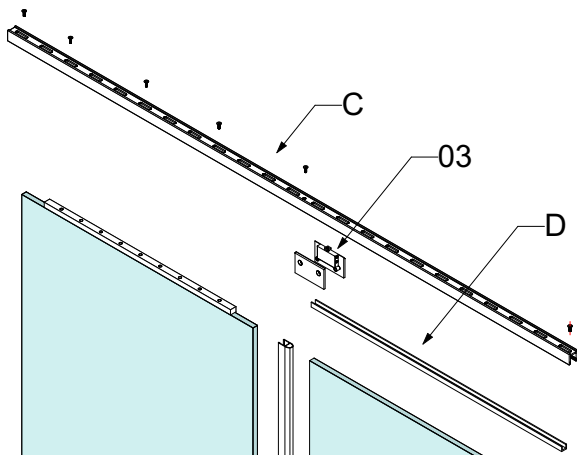
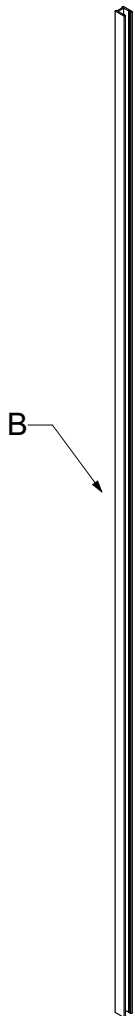

01

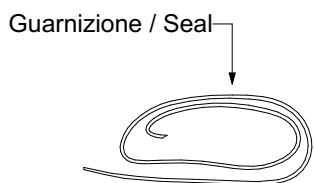
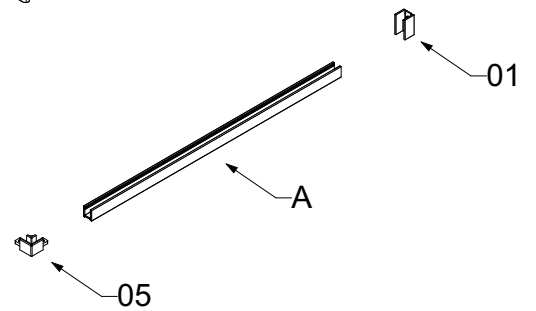
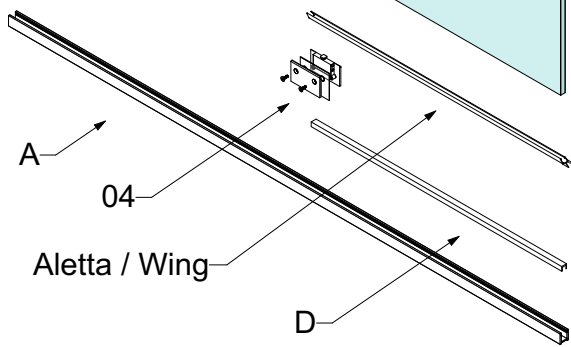

**PROFILI / PROFILE**

**A** BARRA INFERIORE

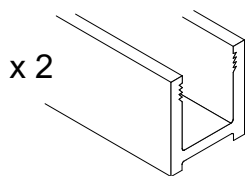

**B** VERT

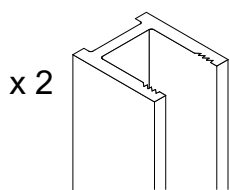

**C** BARRA SUPERIORE

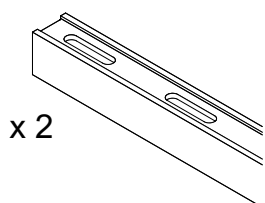

**D** COPRICAVA

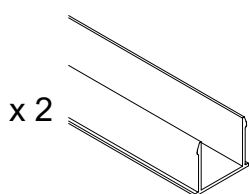

**INNESTI / JOINT**

**01** IN11

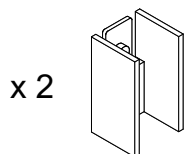

**02** IN11+IN09

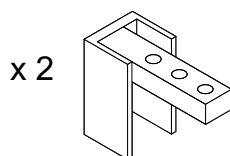

**03** CERNIERA SUPERIORE

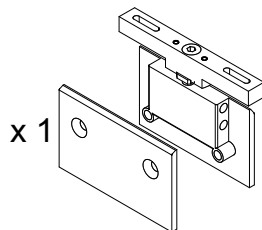

**04** CERNIERA INFERIORE

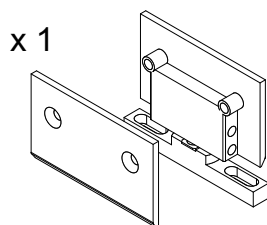

**05** PBLNS00502

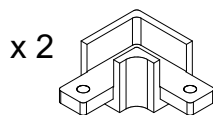

**GUARNIZIONI / SEAL**

PALLONCINO /  
BALOON SEAL  
GV04

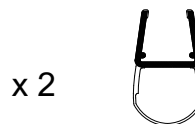

ALETTA / WING SEAL

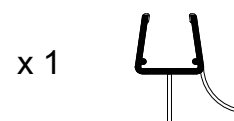

GUARNIZIONE PROFILO /  
PROFILE SEAL  
GS01



VITI FISSAGGIO  
FIXING SCREW

x 16



MANIGLIA-POMOLO  
HANDLE-KNOB

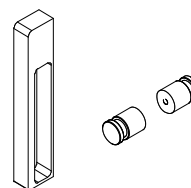

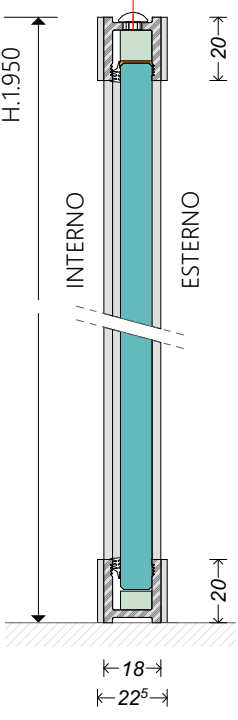
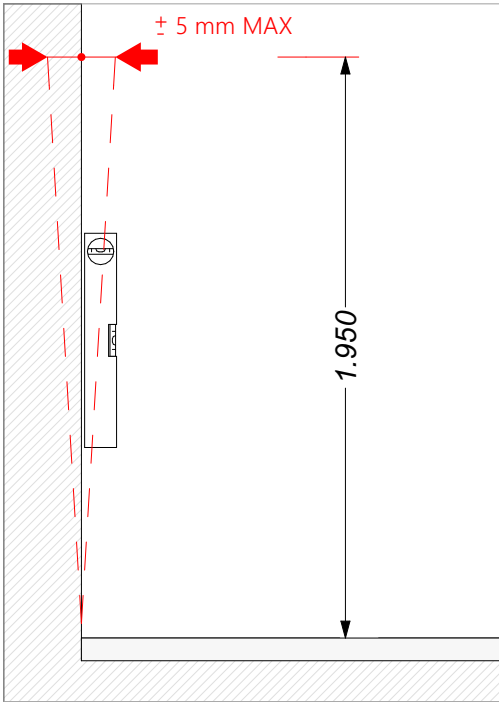
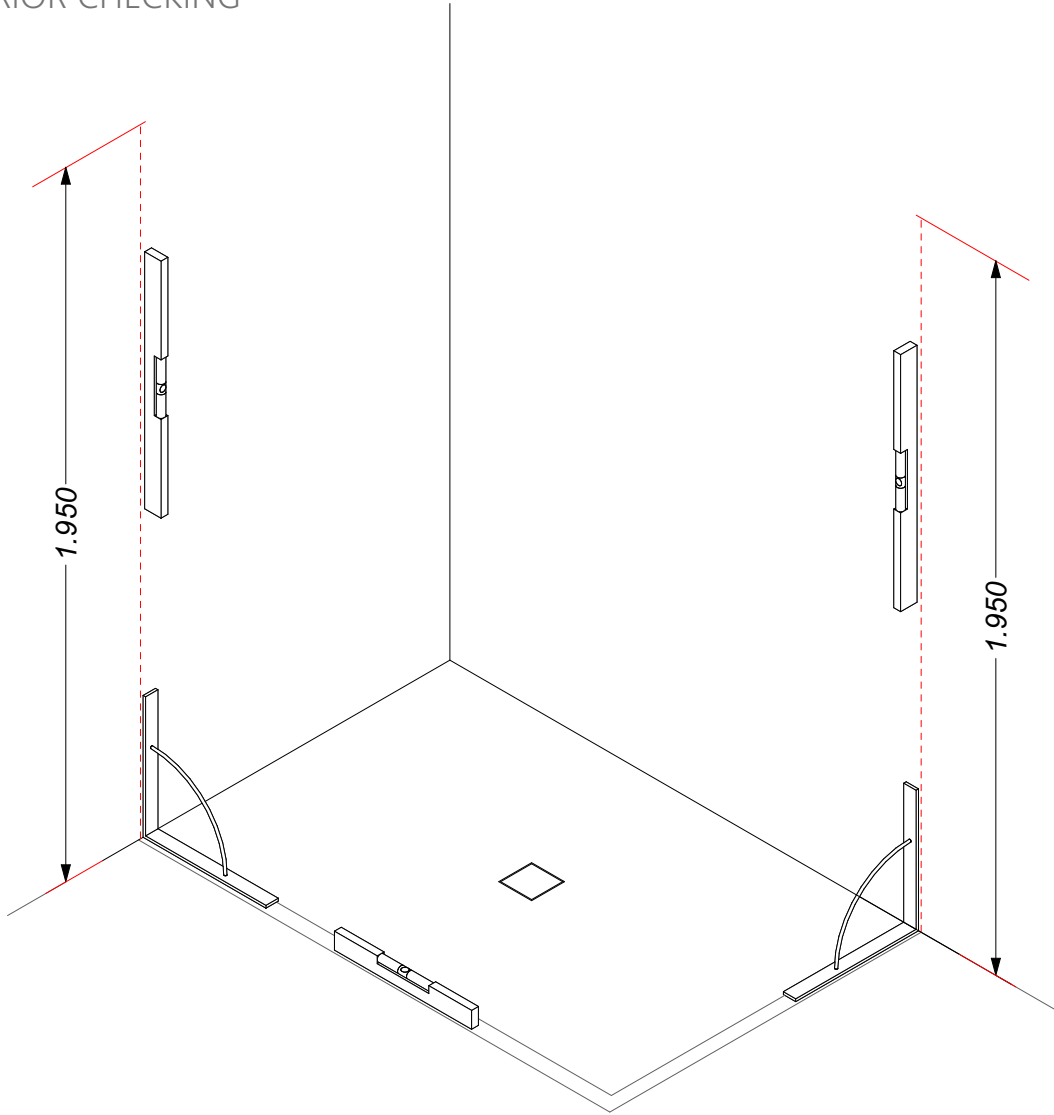



**⚠ ATTENTION**

Individuare il foro di montaggio del perno anta per posizionare correttamente il profilo a terra.

Find the hole for the door's hinge installation, in order to correctly locate the floor profile.

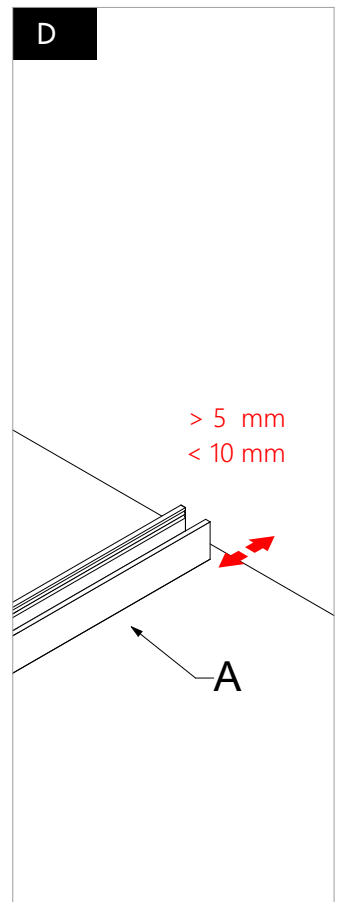
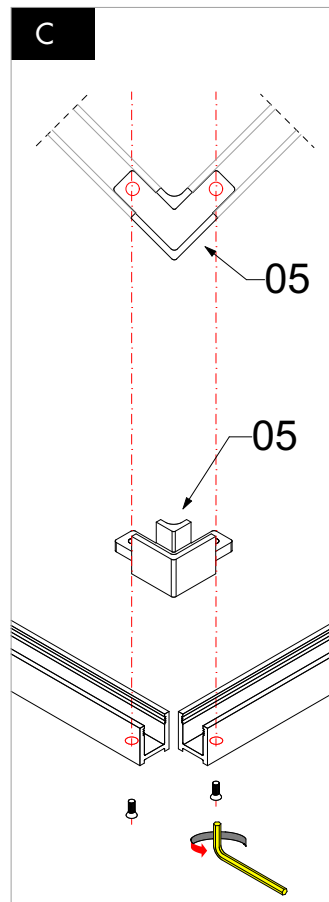
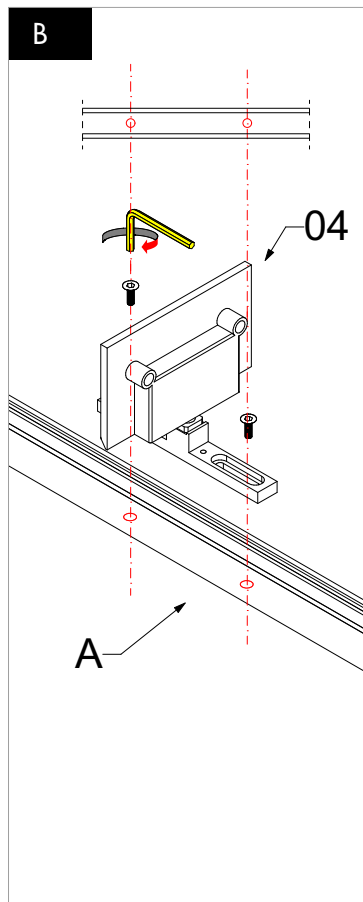
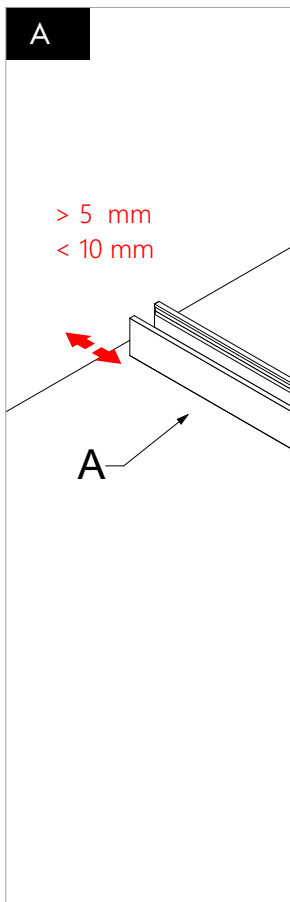
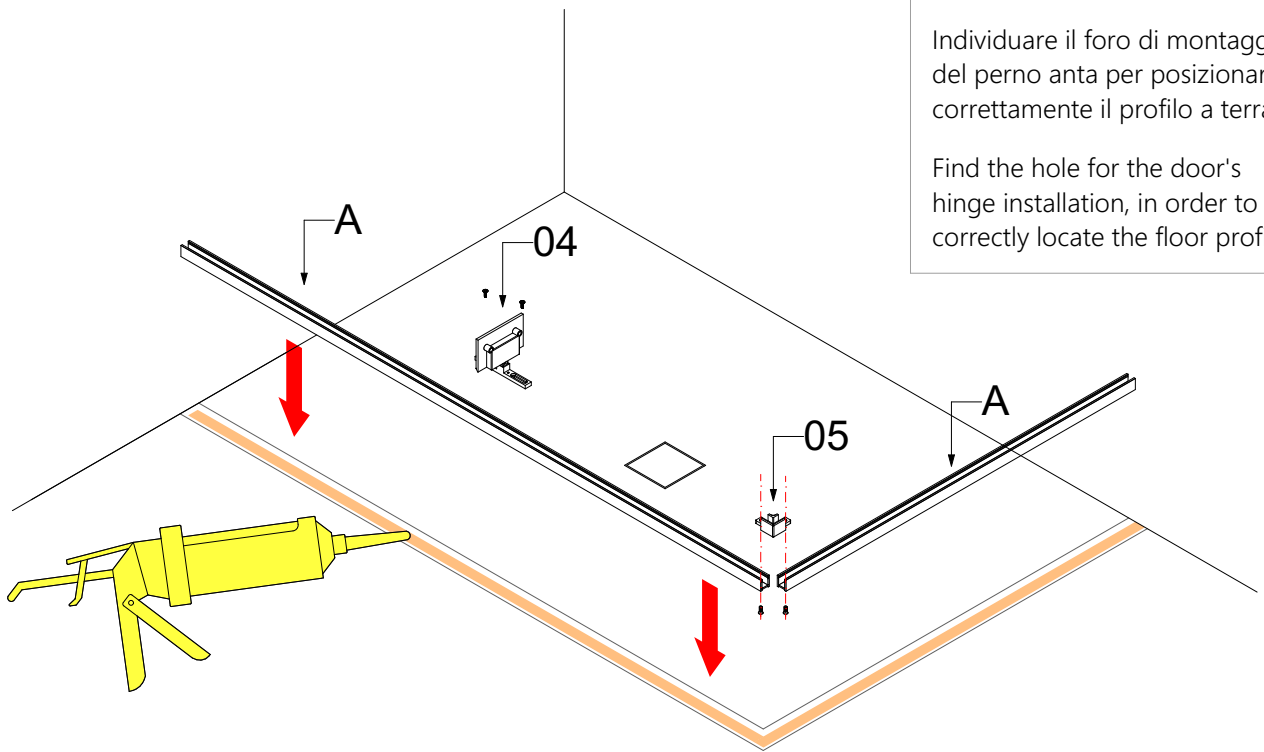



ATTENTION

Attenzione centratura tra innesti e profili.

- Pay attention to the grafts and profiles' centration.

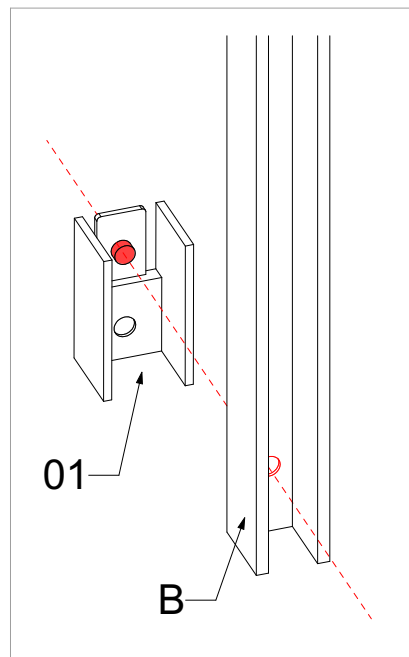
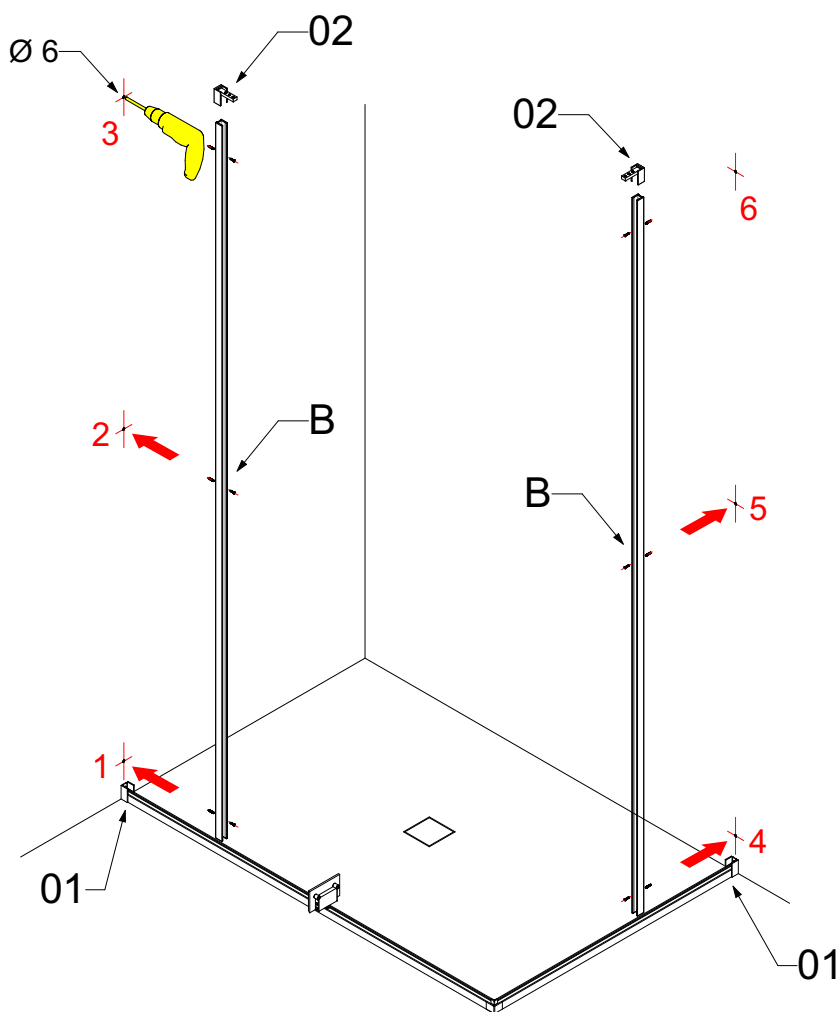

Sinistra / Left

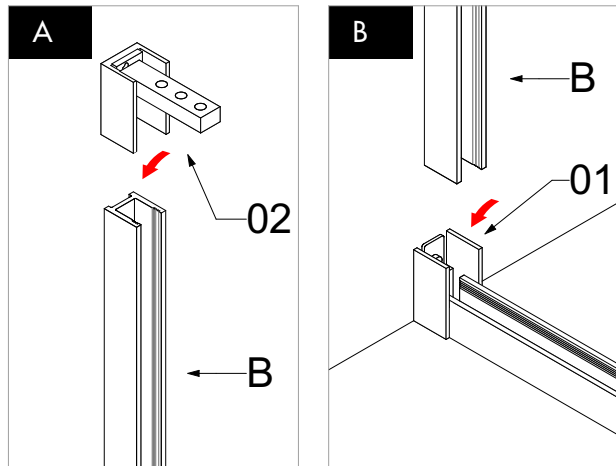

Destra / Right

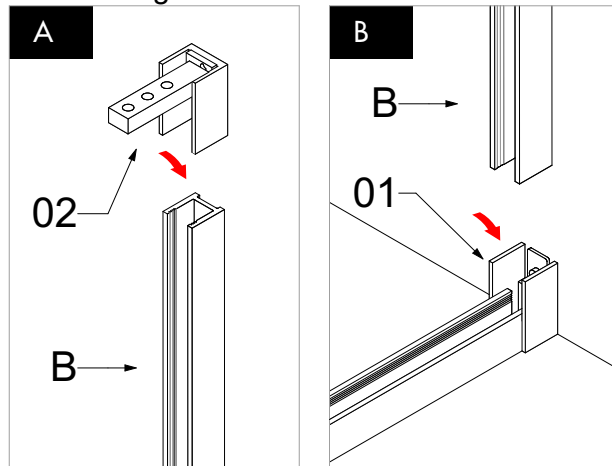



## ATTENTION

Attenzione silliconatura interna innesti.

- Put sylicone on the inner side of the grafts.

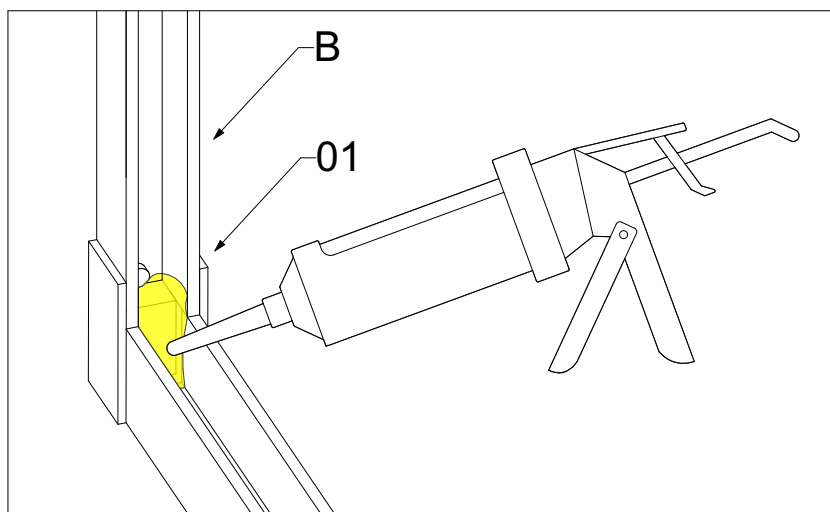
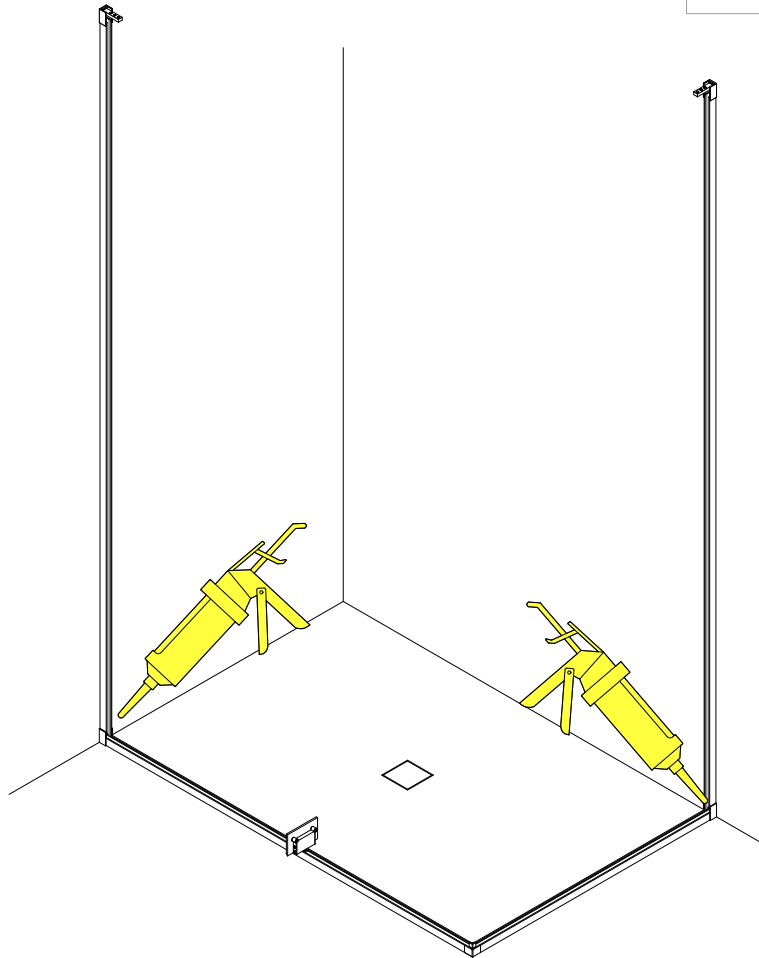

/ 04

INSTALLAZIONE VETRI E BARRA SUPERIORE  
GLASS AND UPPER BAR INSTALLATION

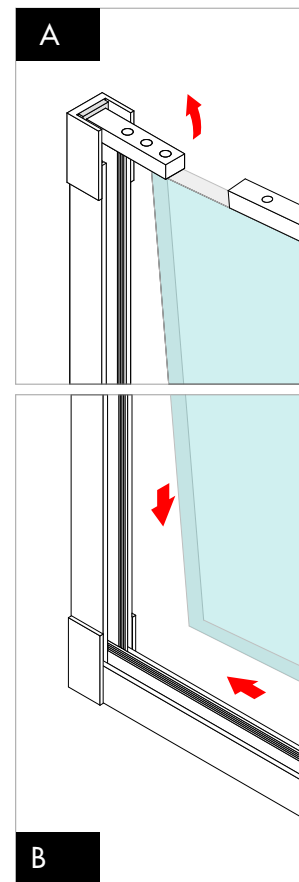
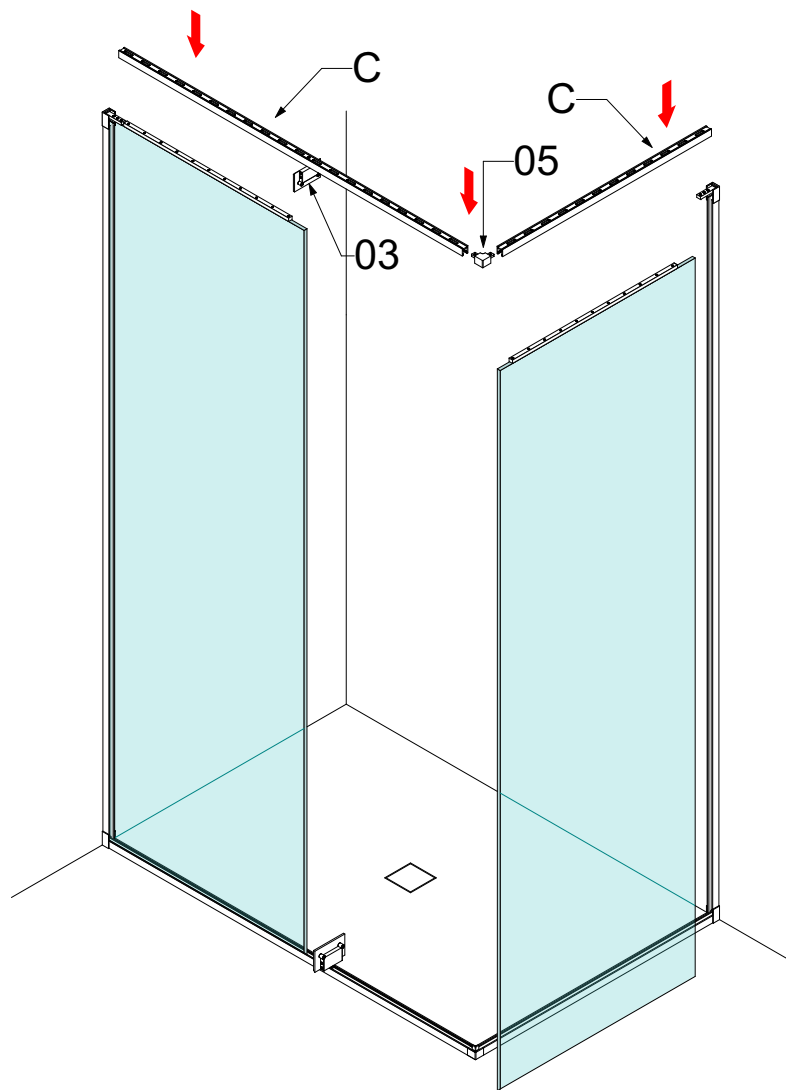

04 a

FISSAGGIO PERNO SUPERIORE  
FIXING OF THE UPPER HINGES

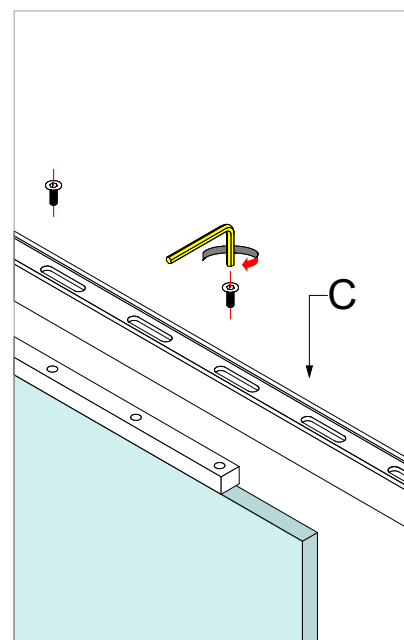
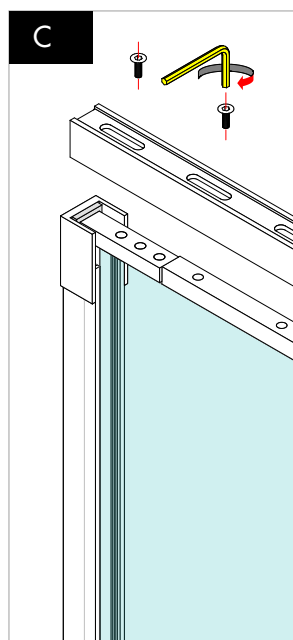
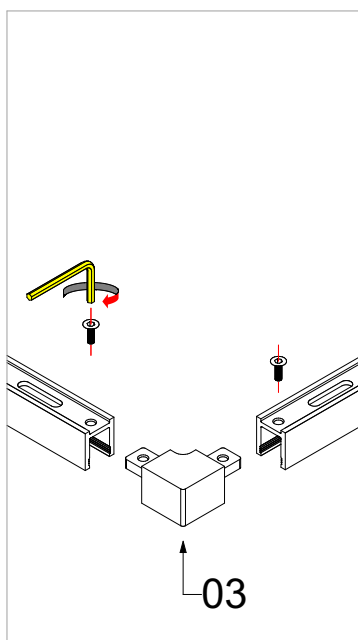
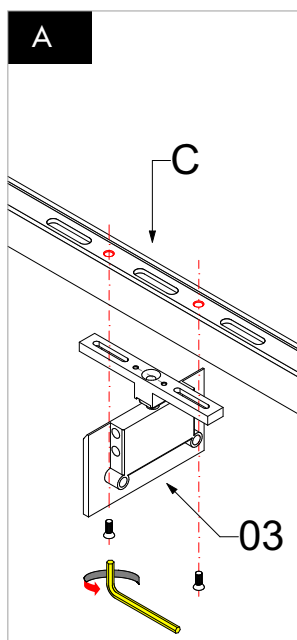

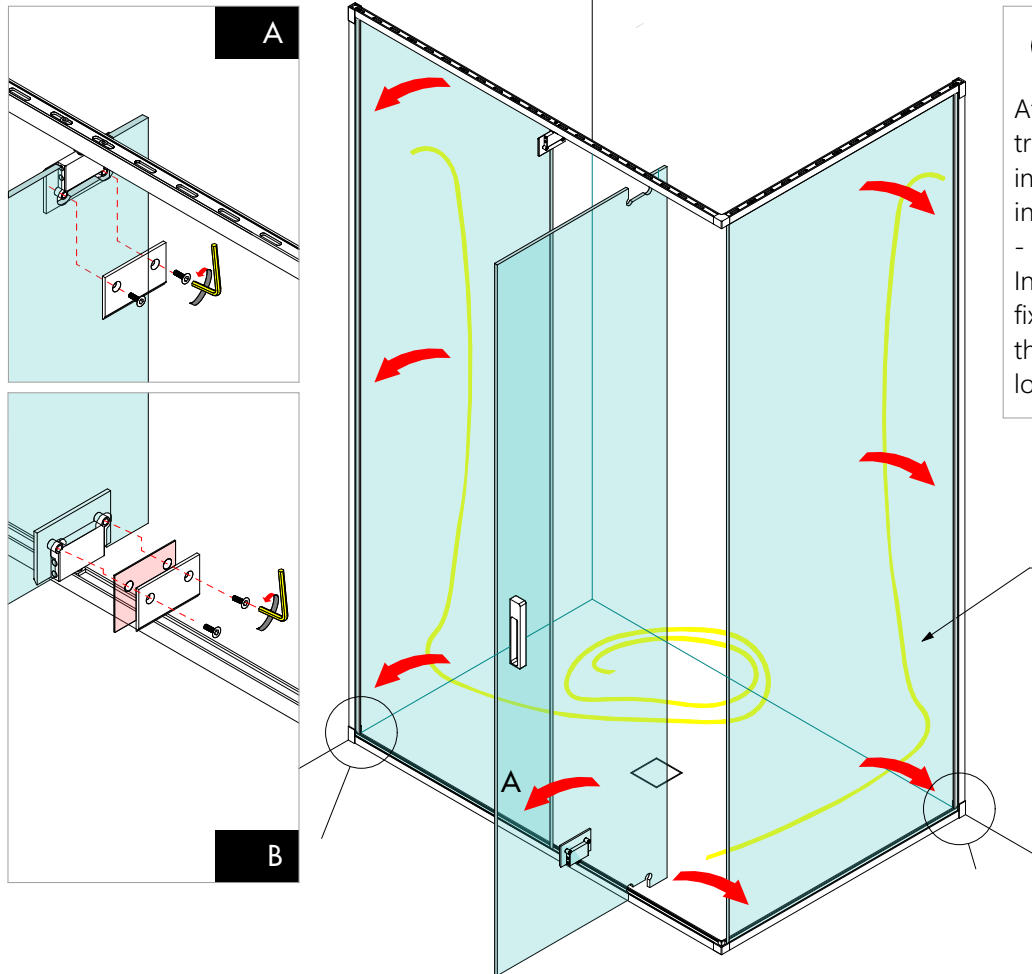

Attenzione applicare guarnizione tra vetro fisso e profilo sul lato interno, senza tagli nell'angolo inferiore.

- Install the gasket between the fixed glass and the inner side of the profile, do not cut on the lower corner.

GUARNIZIONE PROFILO /  
PROFILE SEAL  
GS02

Vista dall'interno / Inside view

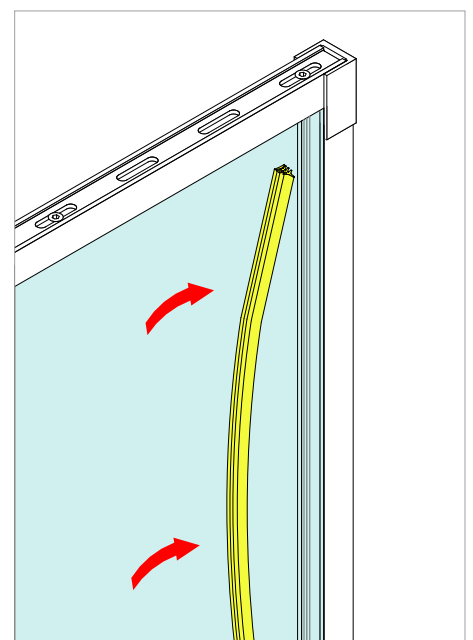
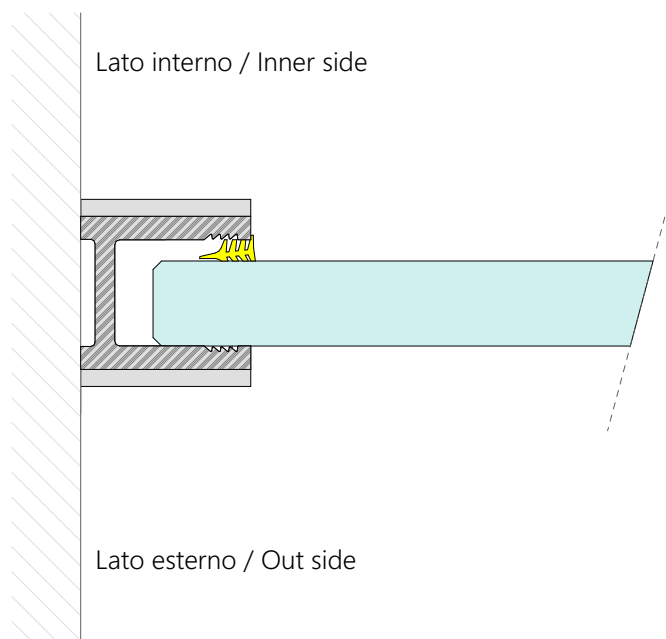



Silicone neutro non acetico  
 antimuffa  
 -  
 Neutral acetic anti-mold sylicone

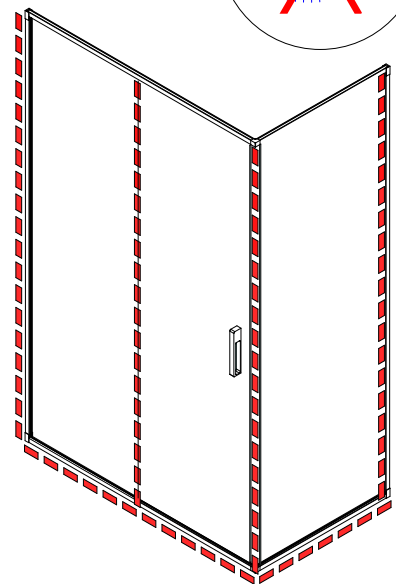
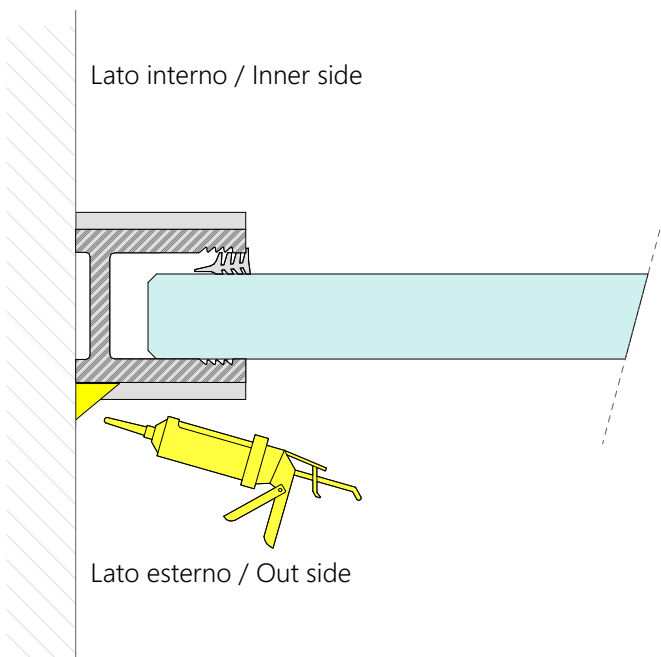
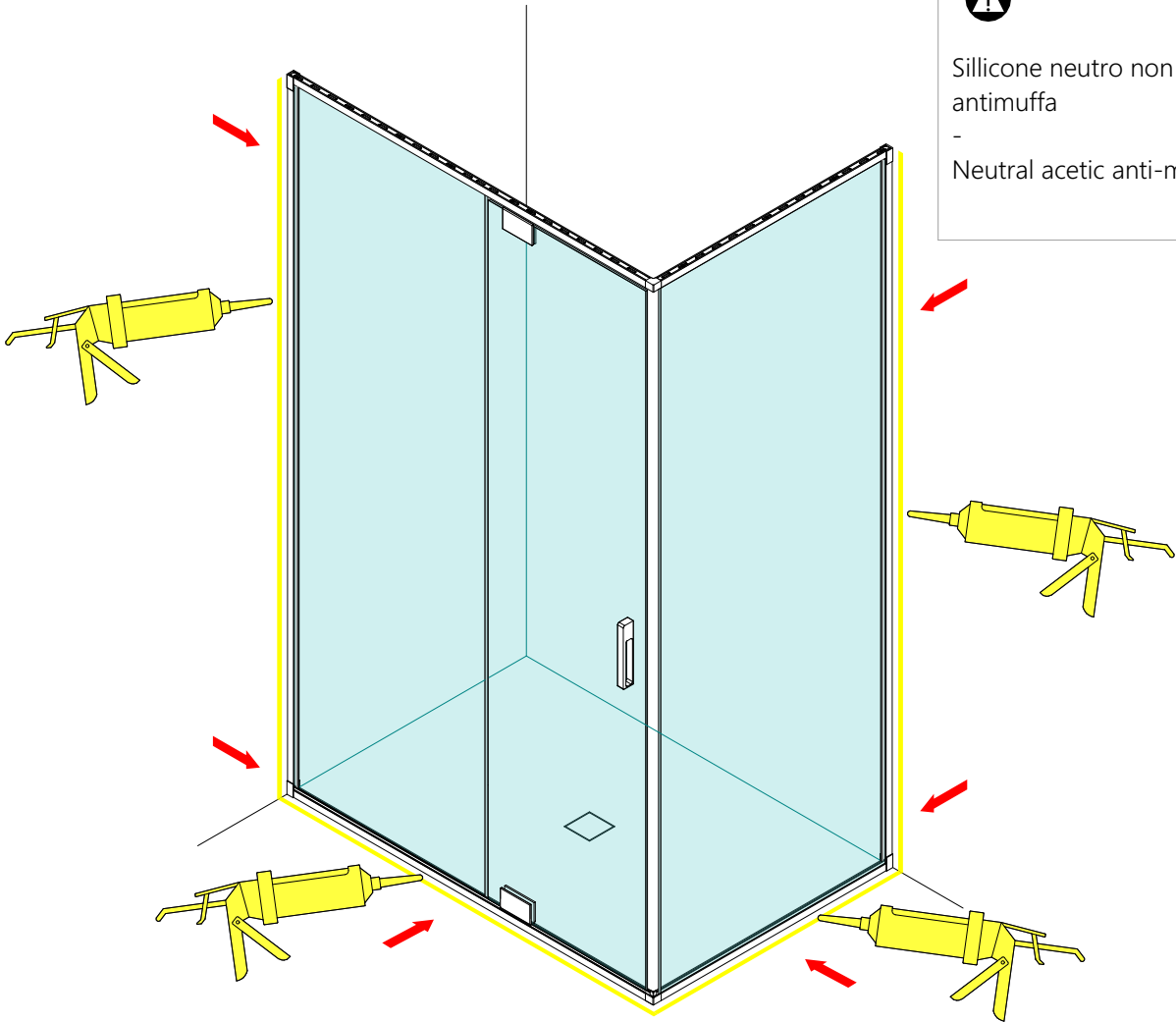

APPLICAZIONE GUARNIZIONI BATTENTE + STOP SUPERIORE  
INSTALLATION OF THE HINGED GASKET + UPPER LOCK

⚠  
Silicone neutro non acetico  
antimuffa  
-  
Neutral acetic anti-mold silicone

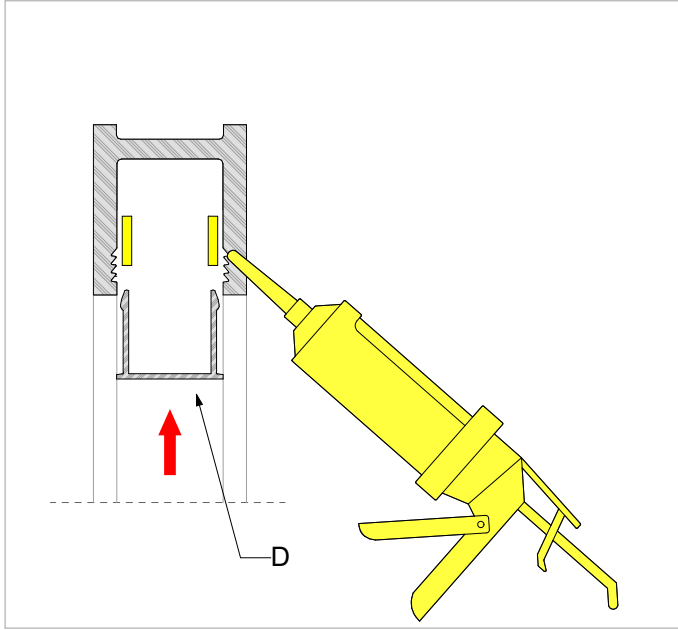
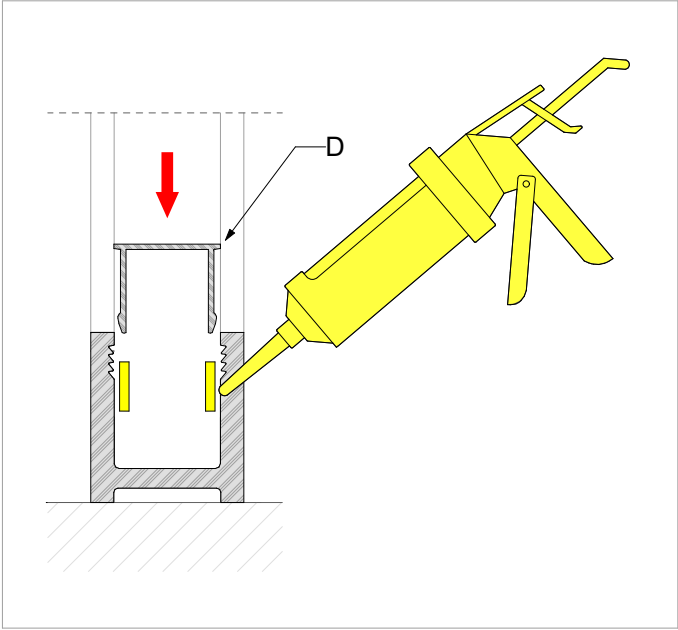
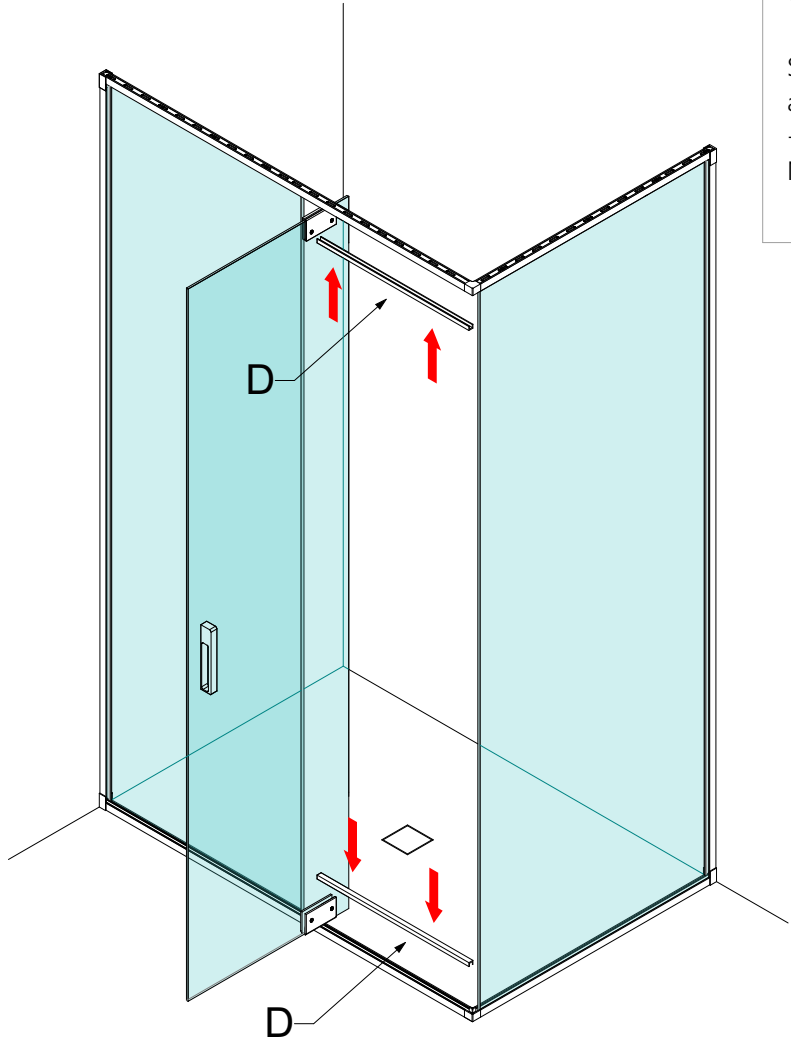

APPLICAZIONE COPRICAVA SUP. + INF.  
UPPER AND LOWER COVER INSTALLATION

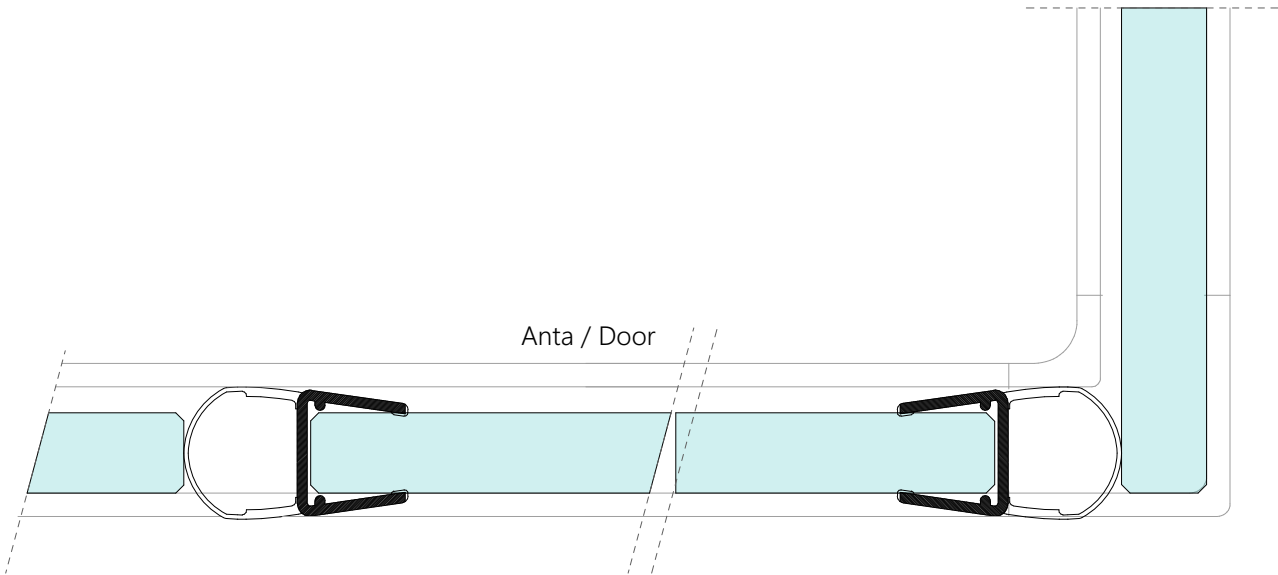
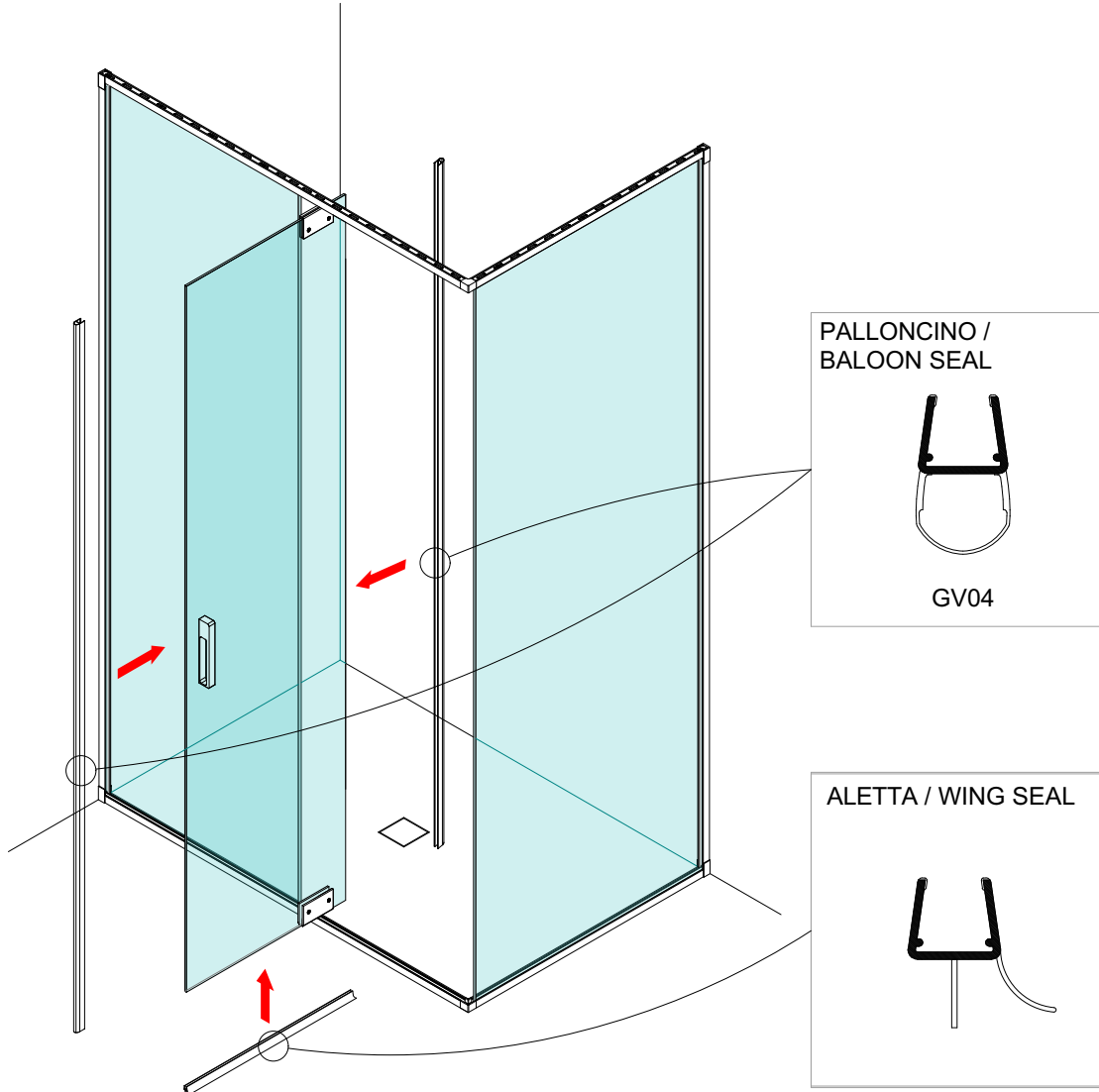



# SPIN TUTTA ALTEZZA\_PBNA assembly

nicchia / niche

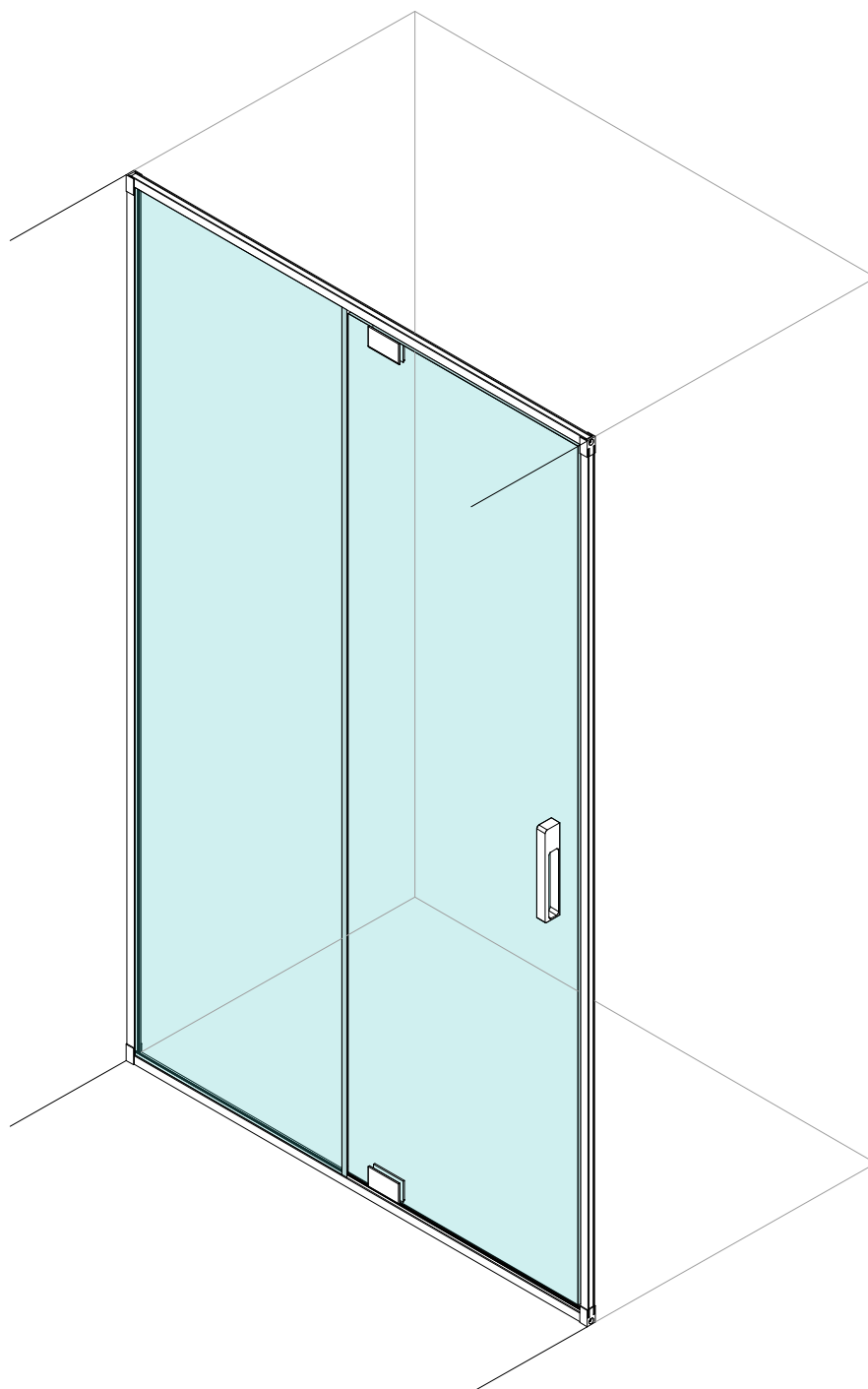
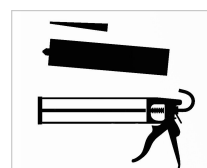
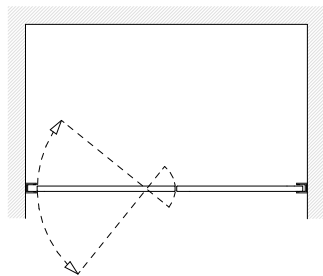
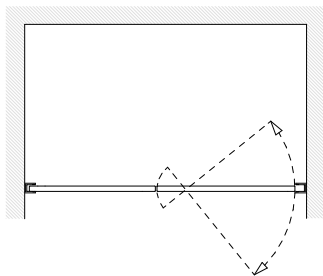



**PROFILI / PROFILE**

**A** BARRA INFERIORE

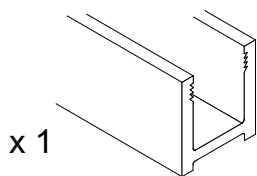

**B** VERT

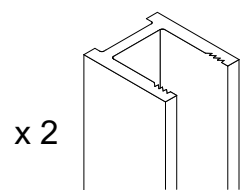

**C** BARRA SUPERIORE

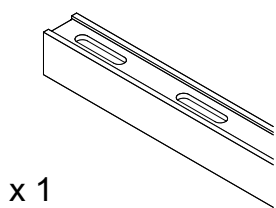

**D** COPRICAVA

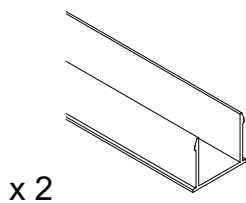

**E** COPRICAVA VERT

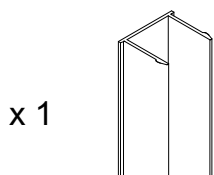

**INNESTI / JOINT**

**01** IN11

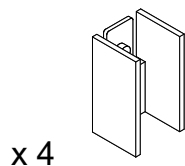

**02** CERNIERA SUPERIORE

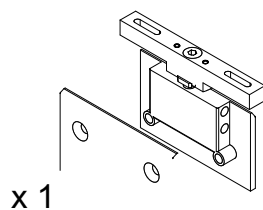

**03** CERNIERA INFERIORE

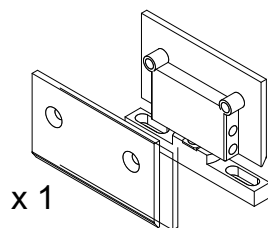

**GUARNIZIONI / SEAL**

PALLONCINO /  
BALOON SEAL  
GV04

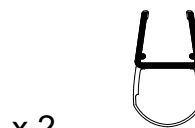

ALETTA / WING SEAL

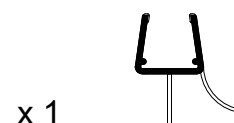

GUARNIZIONE PROFILO /  
PROFILE SEAL  
GS01

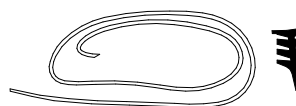

GUARNIZIONE CERNIERA /  
PIVOT SEAL

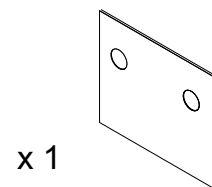

VITI FISSAGGIO  
FIXING SCREW

x 12



MANIGLIA-POMOLO  
HANDLE-KNOB

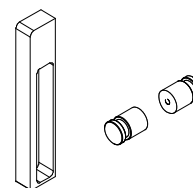

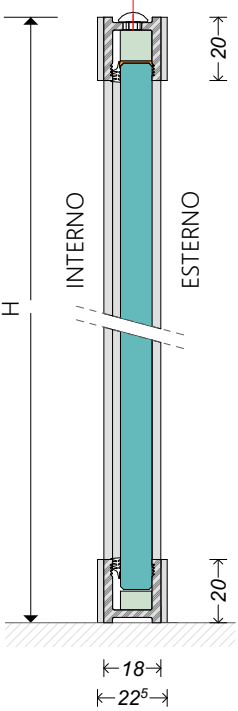
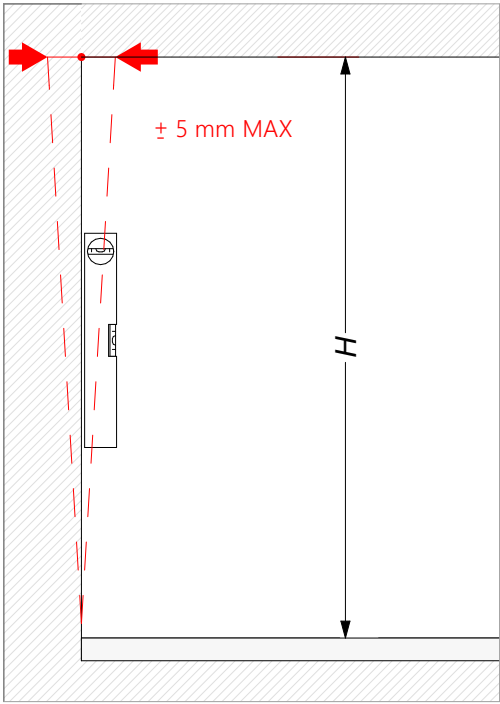
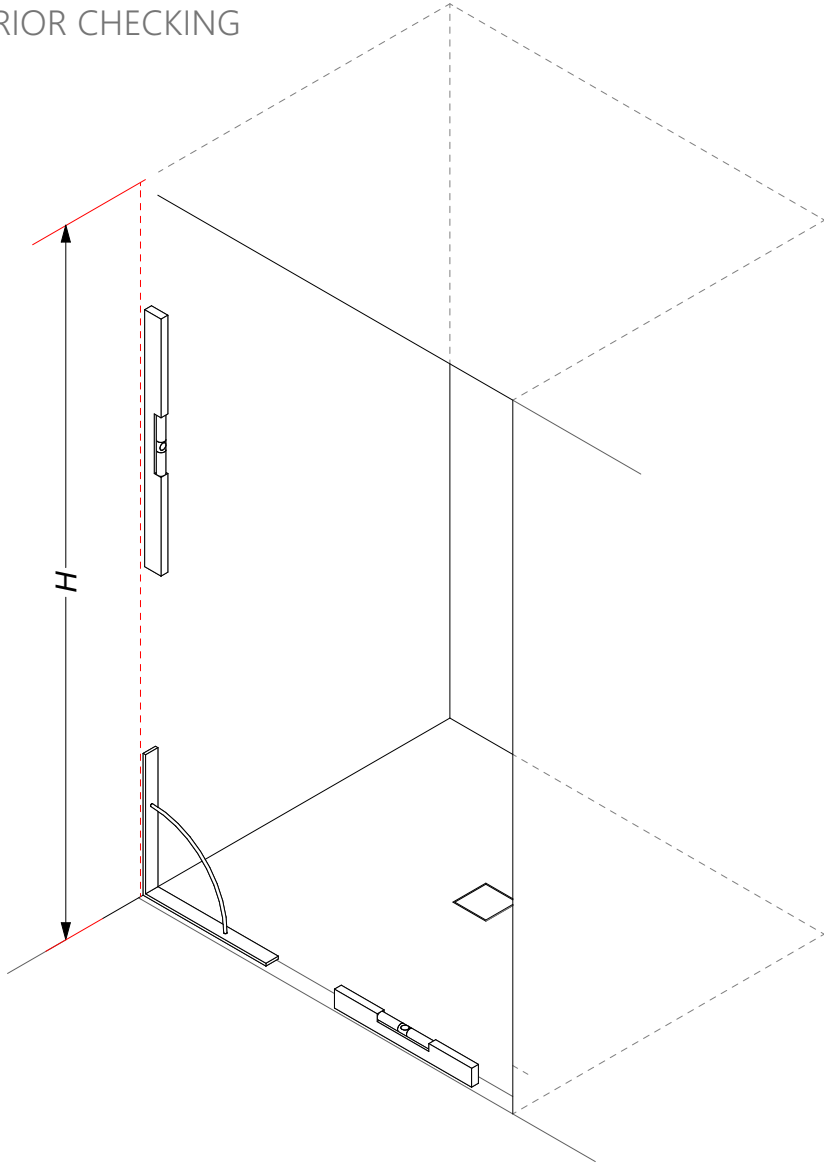

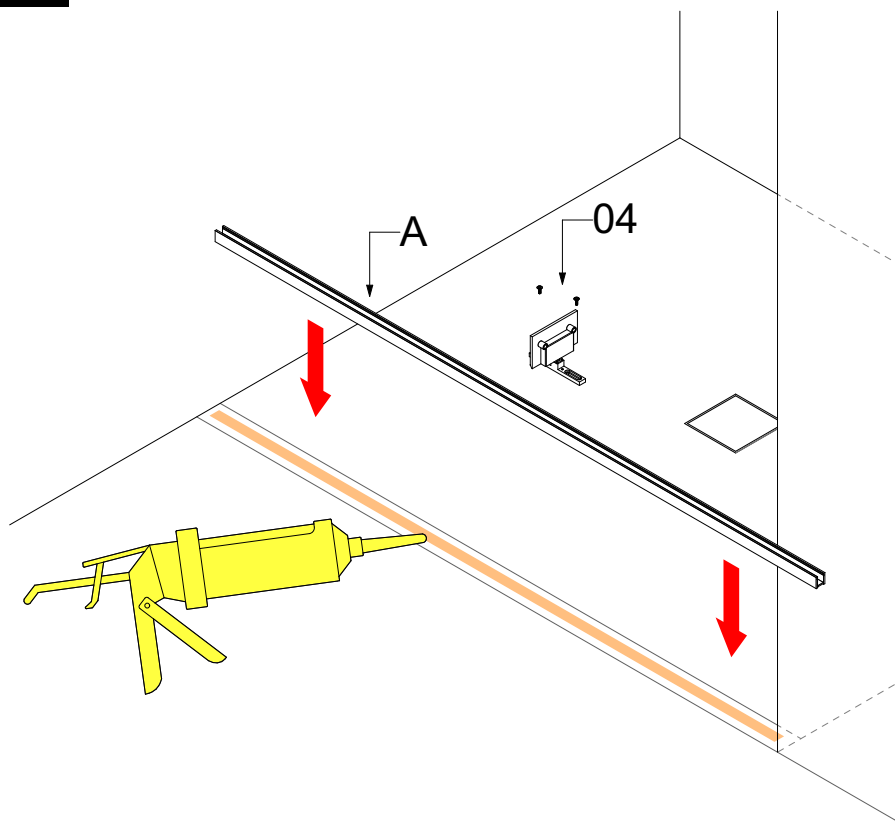

**⚠ ATTENTION**

Individuare il foro di montaggio del perno anta per posizionare correttamente il profilo a terra.

Find the hole for the door's hinge installation, in order to correctly locate the floor profile.

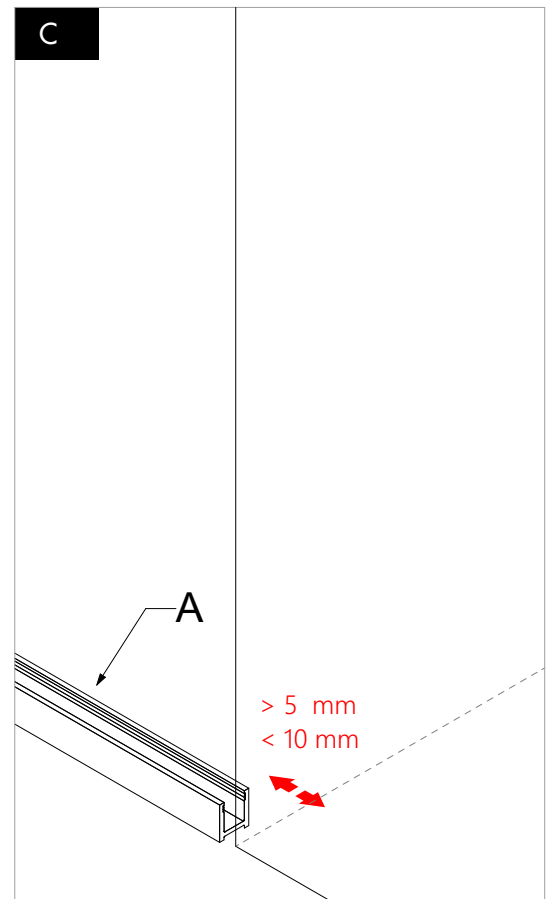
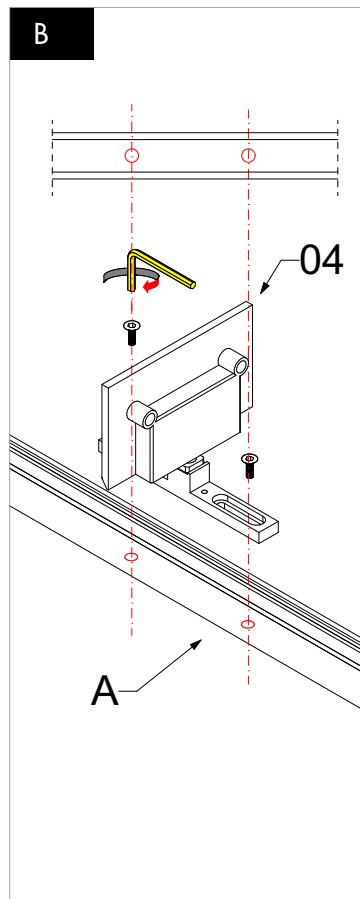
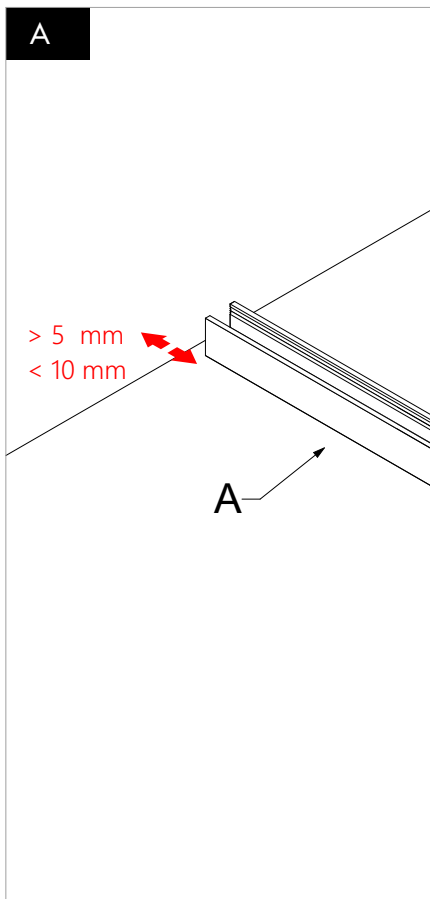

**⚠ ATTENTION**

Individuare il foro di montaggio del perno anta per posizionare correttamente il profilo a terra.

Find the hole for the door's hinge installation, in order to correctly locate the floor profile.

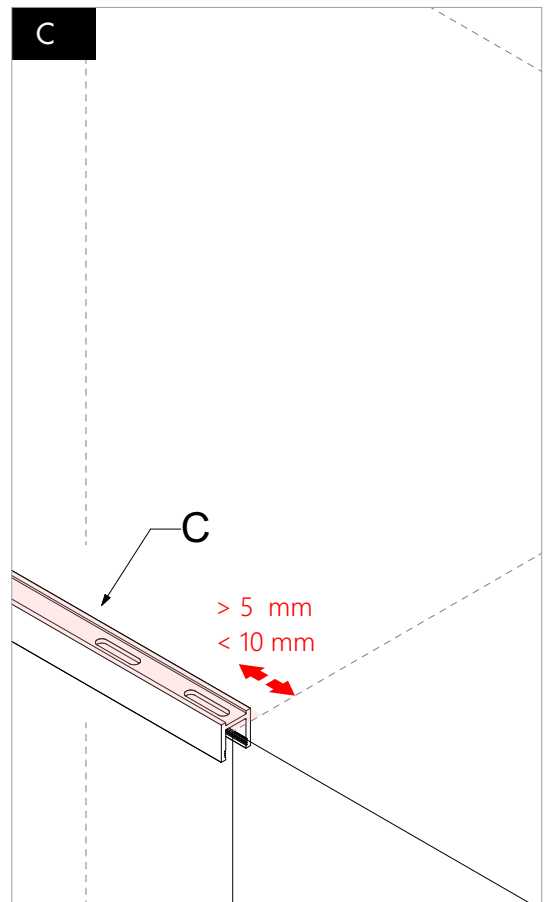
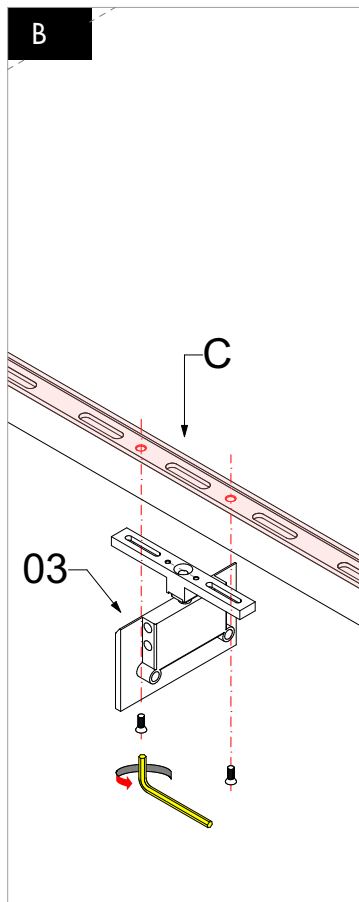
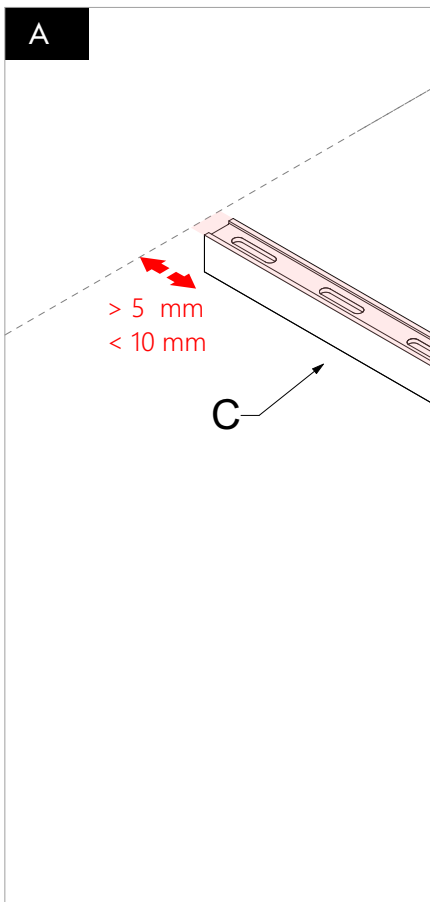
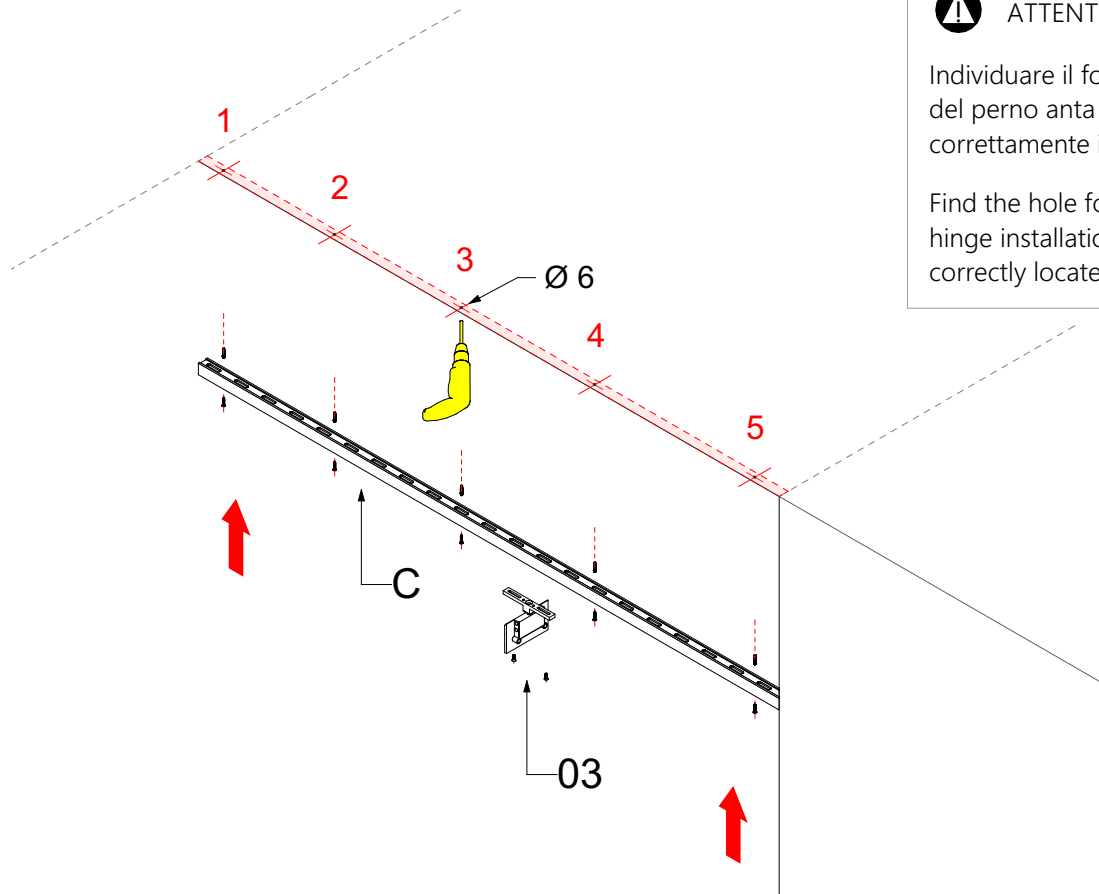



ATTENTION

Attenzione centratura tra innesti e profili.

- Pay attention to the grafts and profiles' centration.

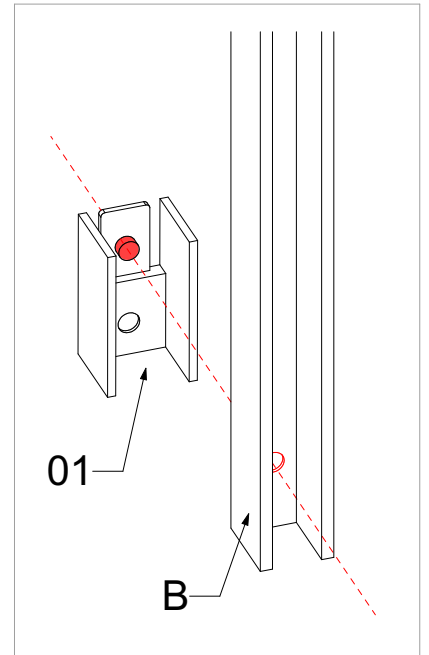
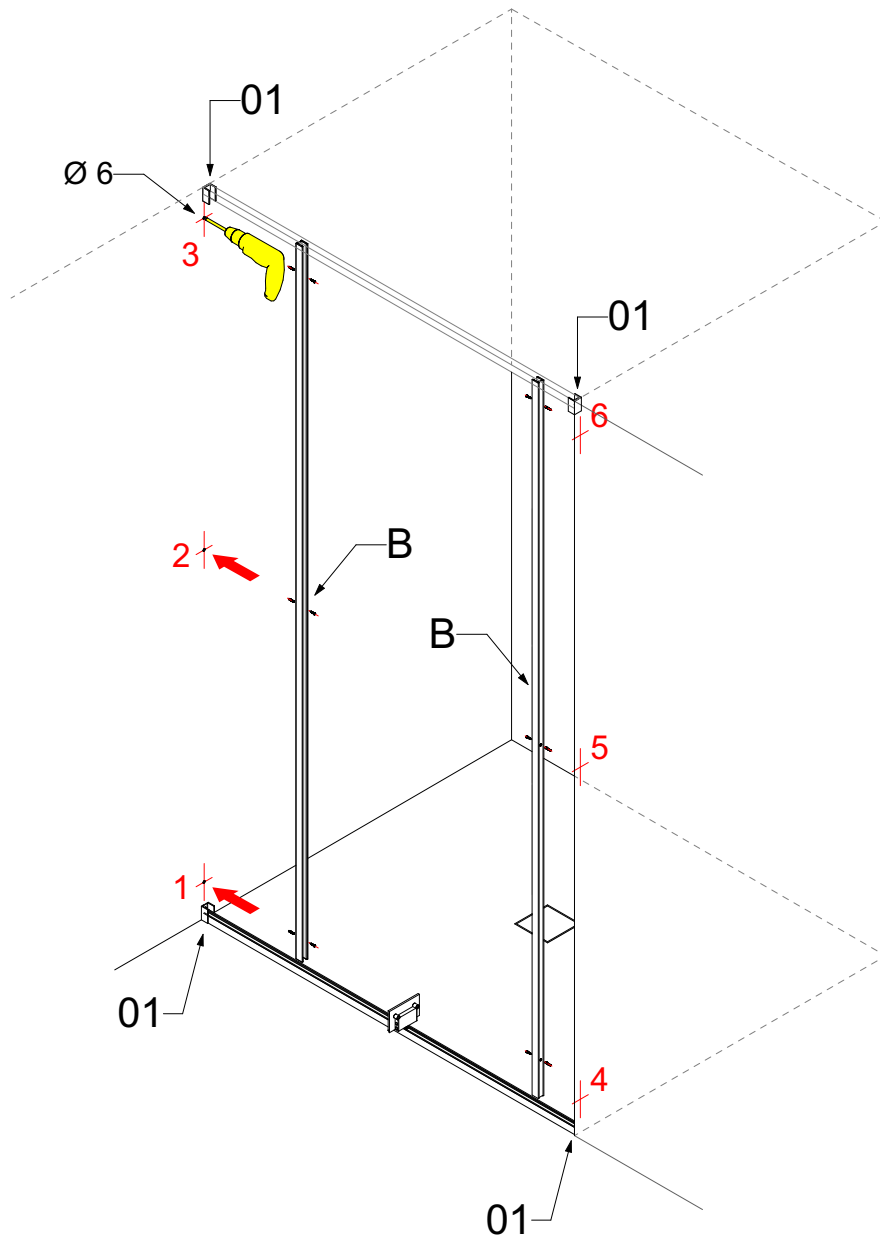

Sinistra / Left

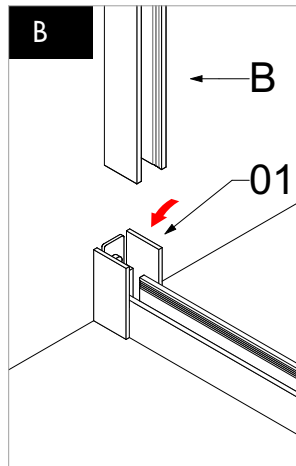
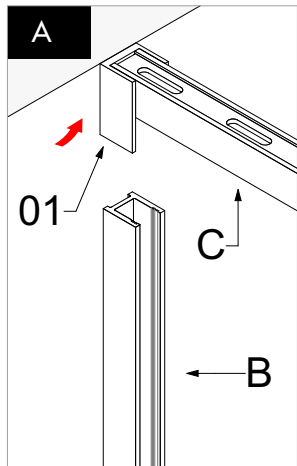

Destra / Right

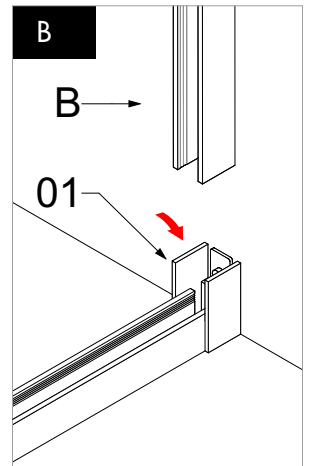
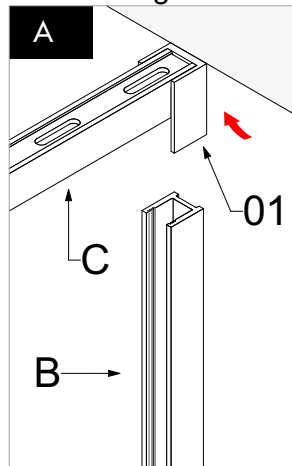



## ATTENTION

Attenzione silliconatura interna innesti.

- Put sylicone on the inner side of the grafts.

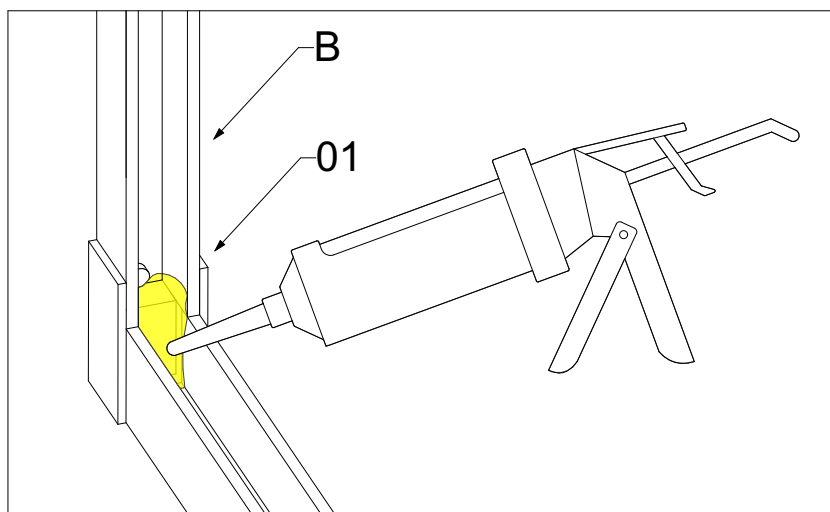
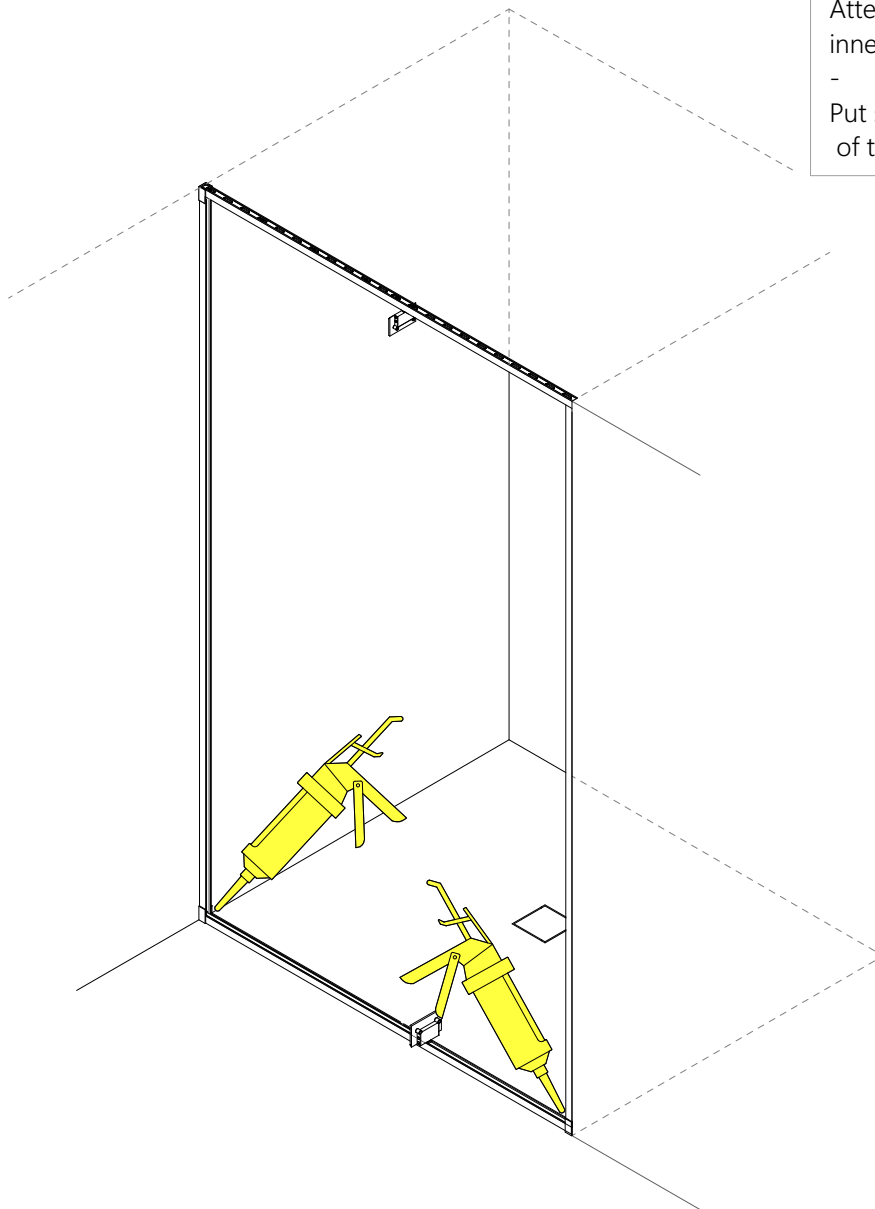



Vetro fisso / Fixed glass

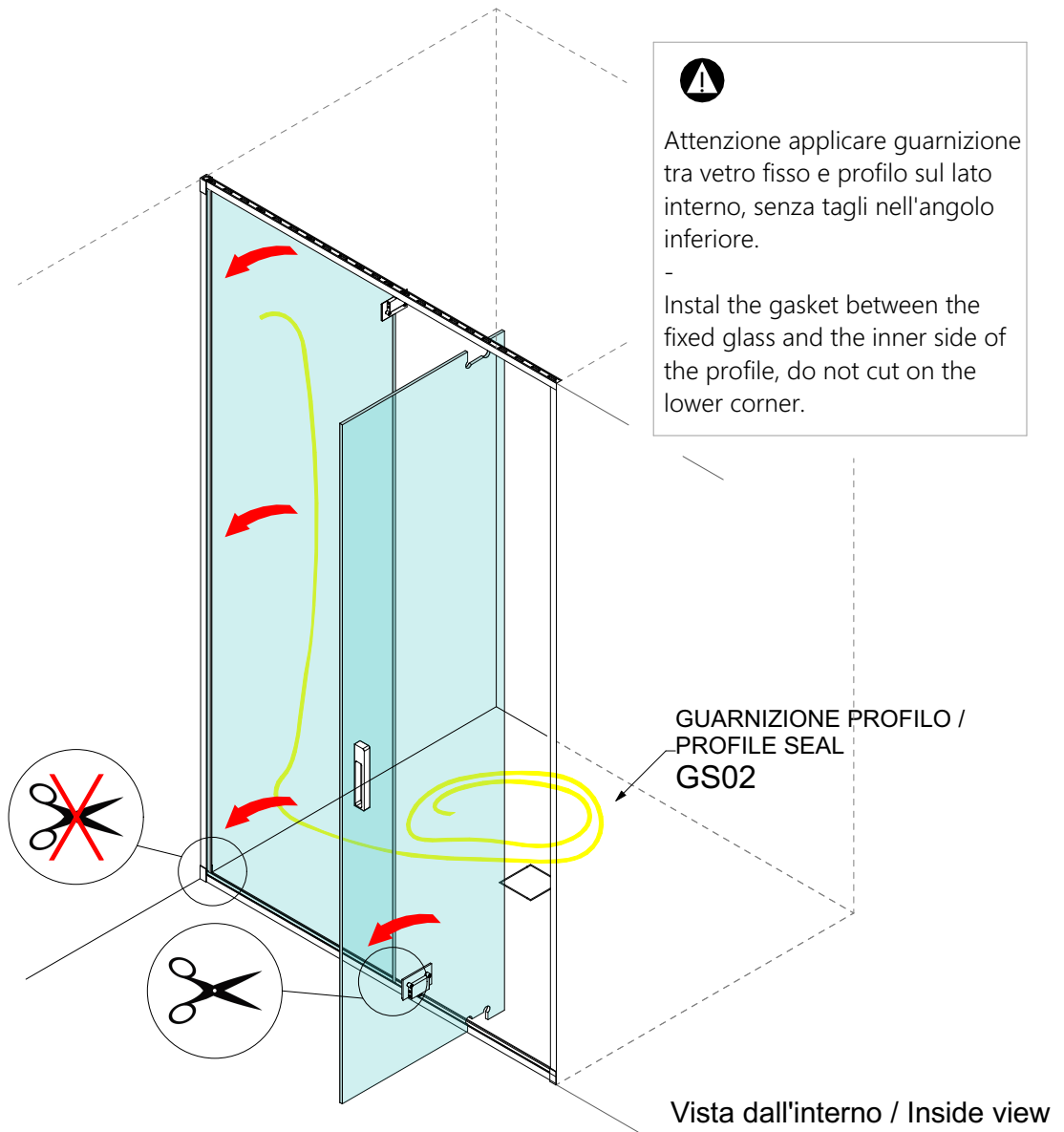
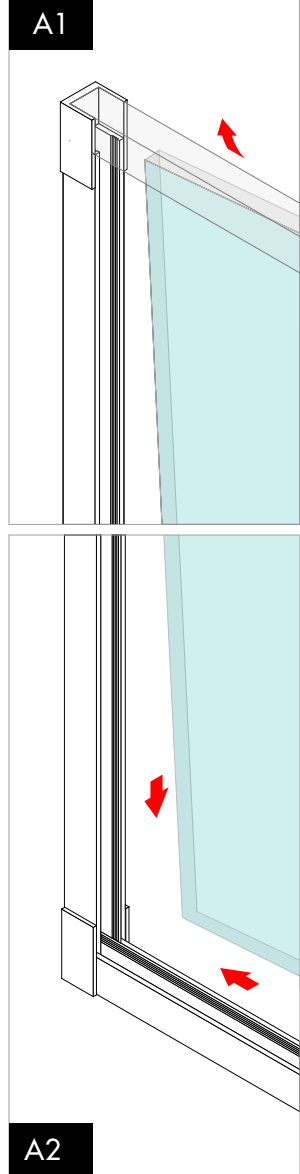

**⚠**  
Attenzione applicare guarnizione tra vetro fisso e profilo sul lato interno, senza tagli nell'angolo inferiore.  
-  
Instal the gasket between the fixed glass and the inner side of the profile, do not cut on the lower corner.

GUARNIZIONE PROFILO /  
PROFILE SEAL  
GS02

Vista dall'interno / Inside view

Anta / Door

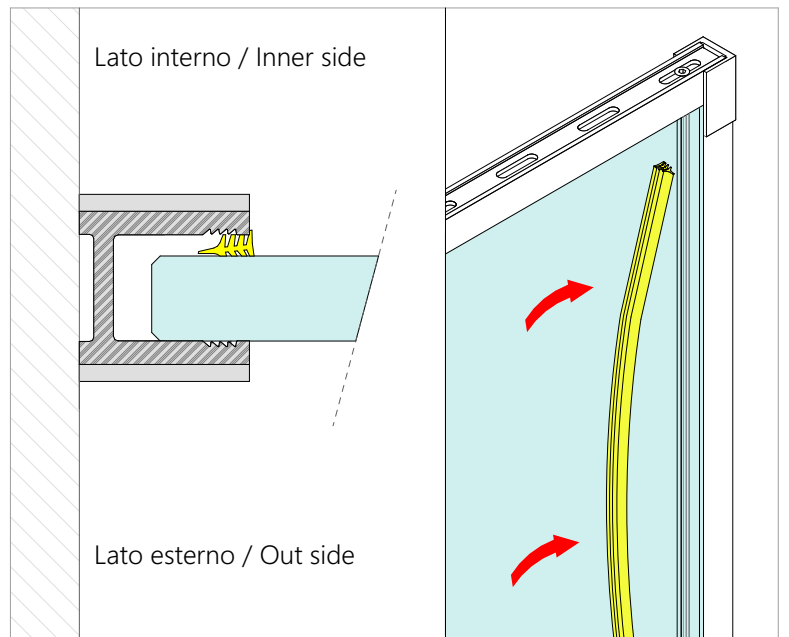
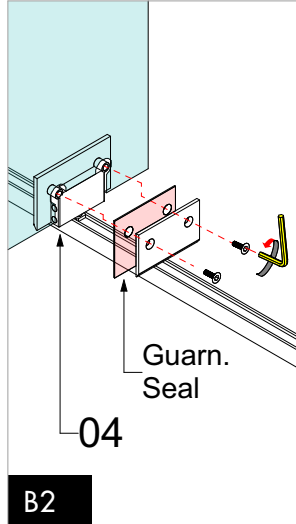
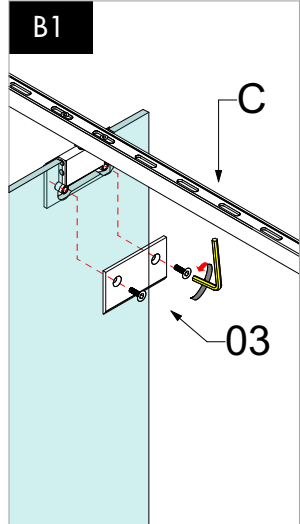



Silicone neutro non acetico  
 antimuffa  
 -  
 Neutral acetic anti-mold sylicone

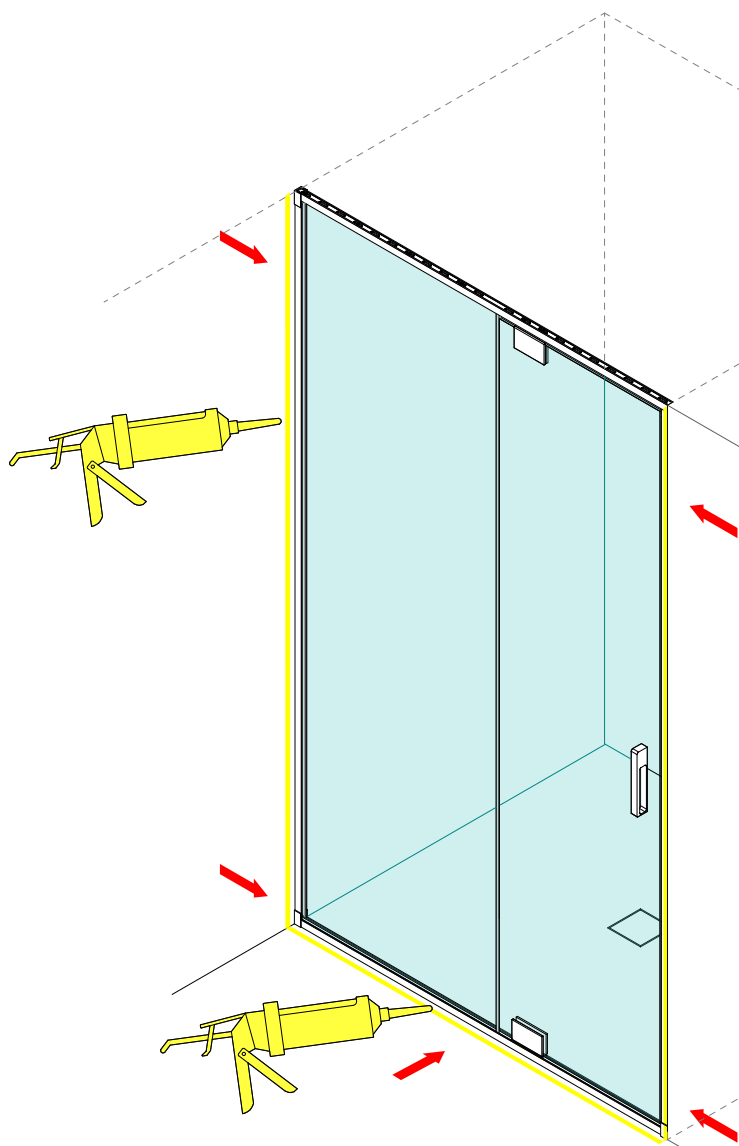

Lato interno / Inner side

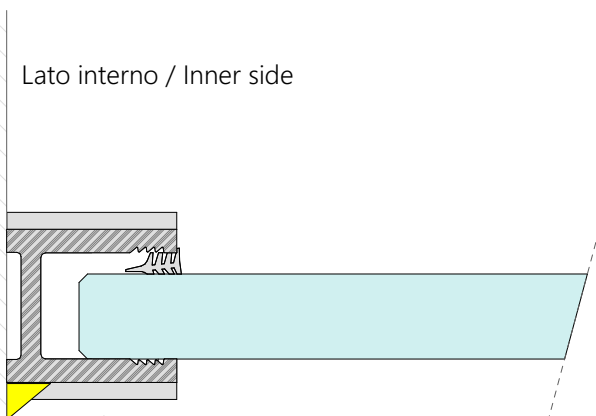

Lato esterno / Out side

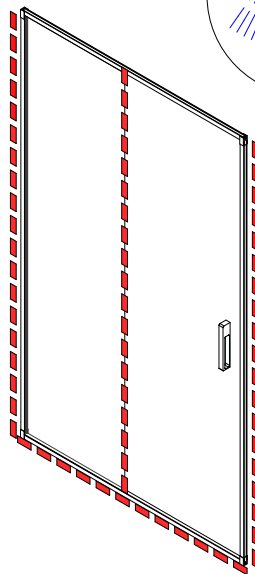
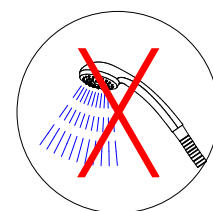

APPLICAZIONE GUARNIZIONI BATTENTE + STOP SUPERIORE  
INSTALLATION OF THE HINGED GASKET + UPPER LOCK

⚠  
Silicone neutro non acetico  
antimuffa  
-  
Neutral acetic anti-mold silicone

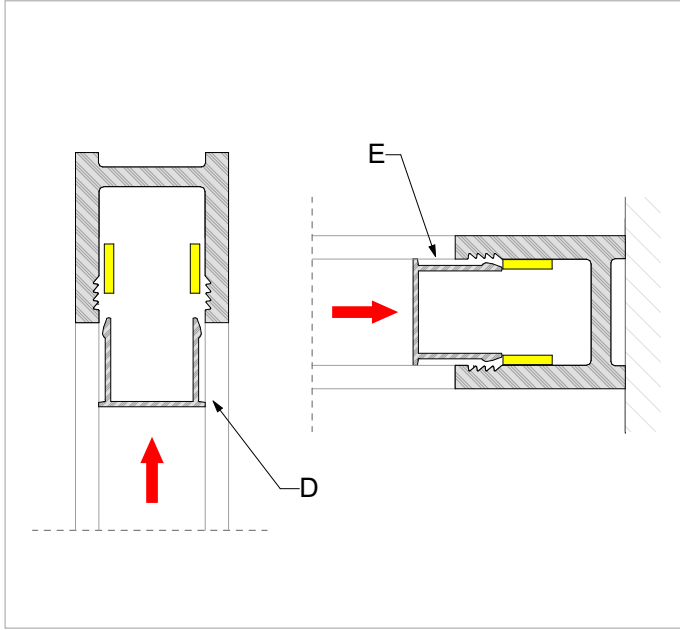
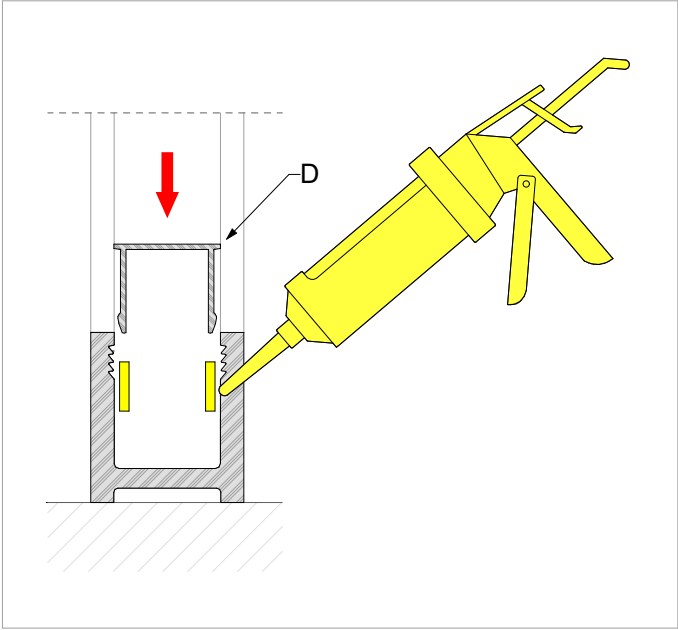
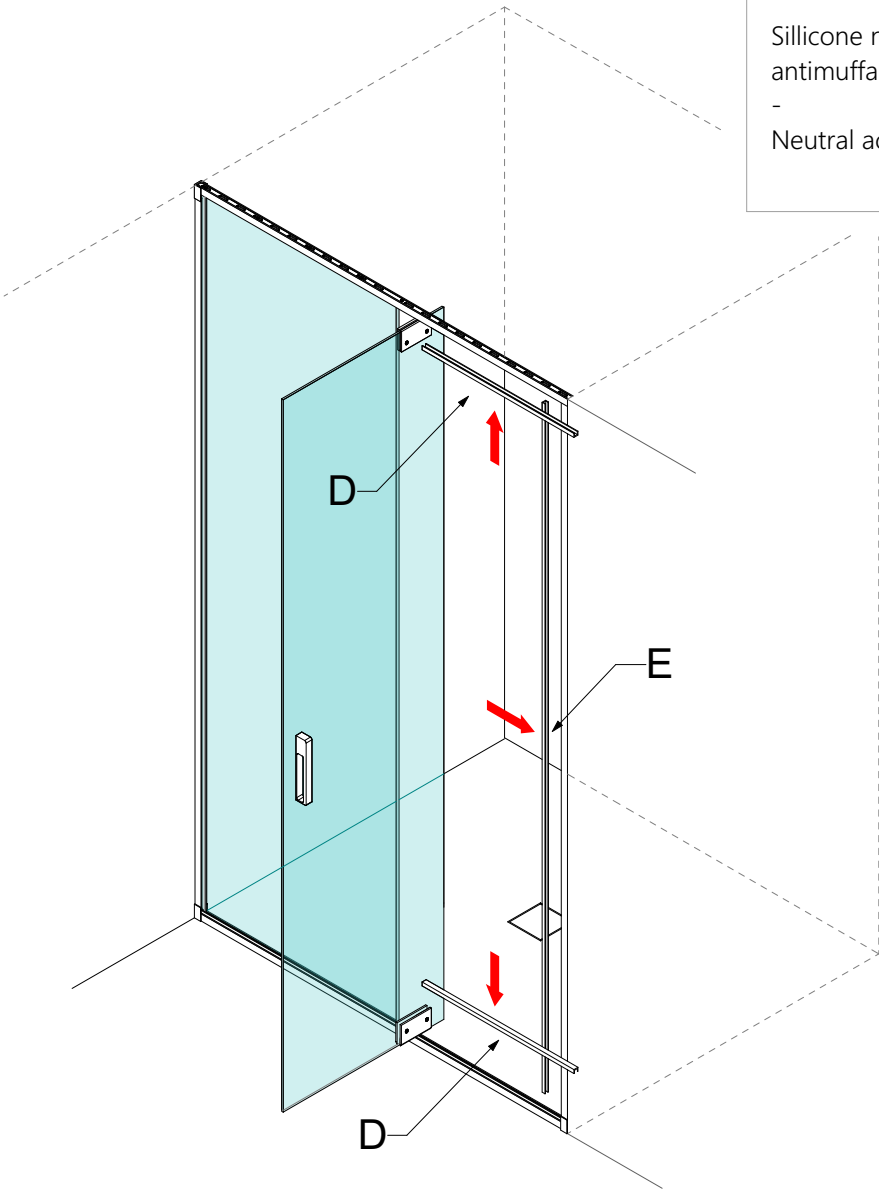

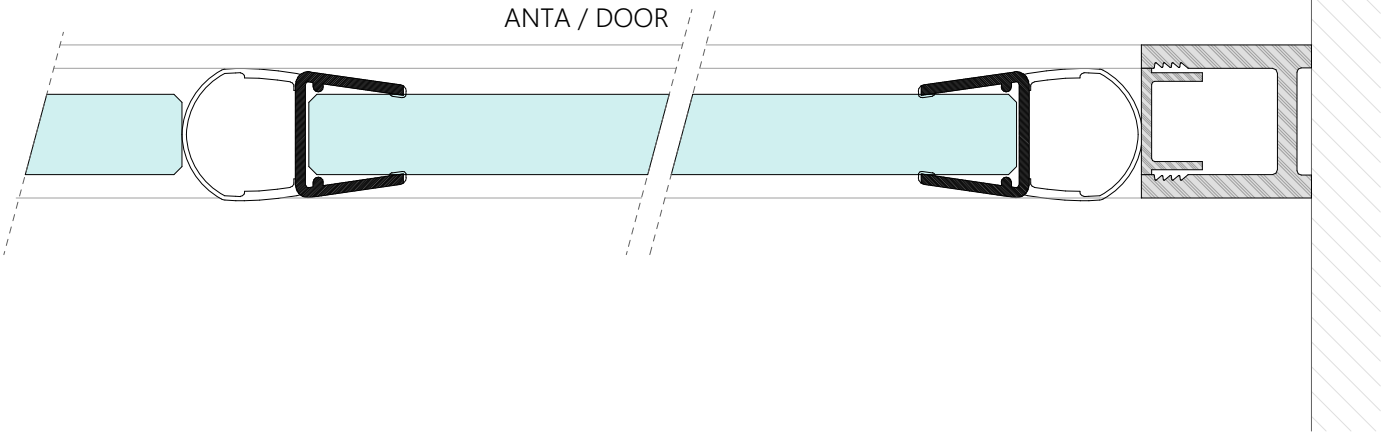
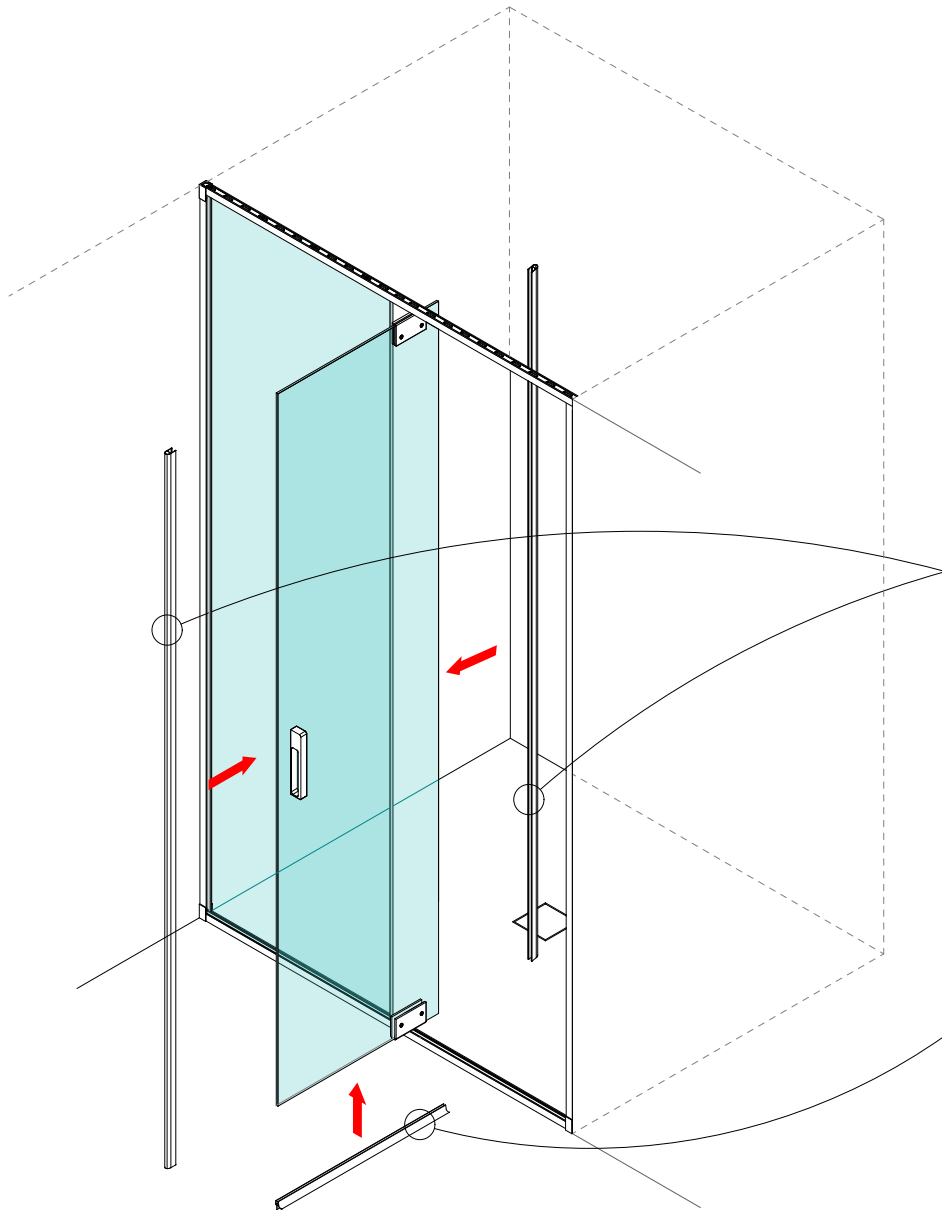

# SPIN TUTTA ALTEZZA\_PBAAssembly

angolo / corner

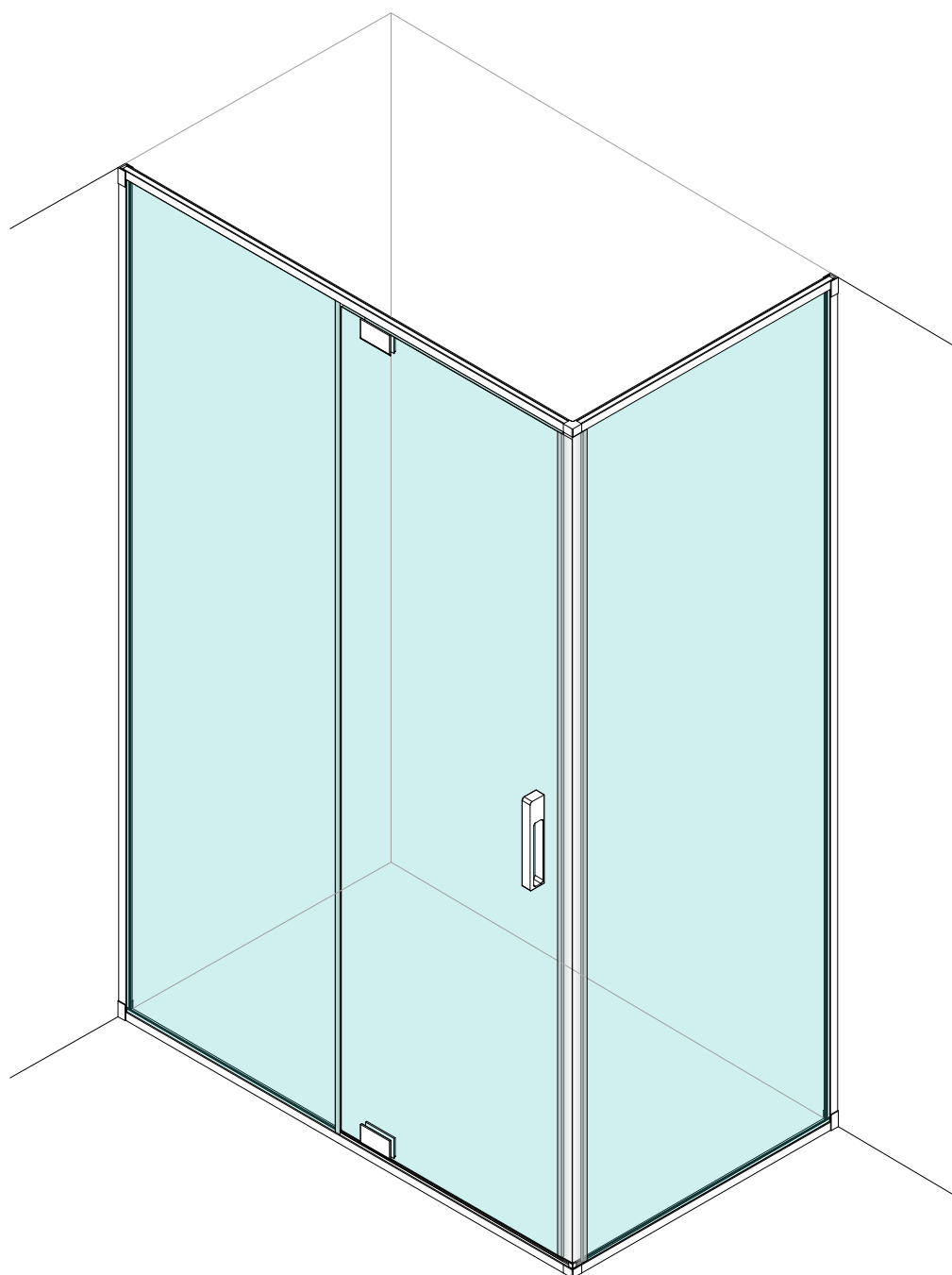
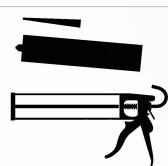
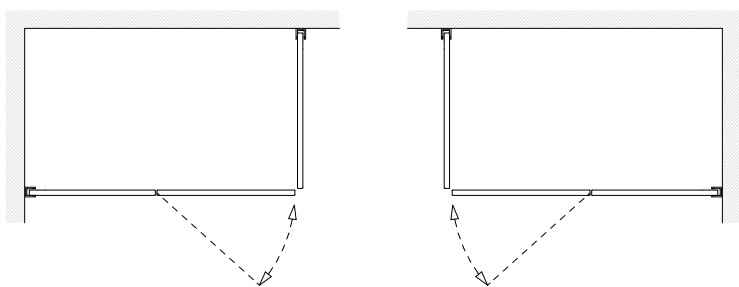

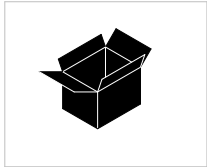

01

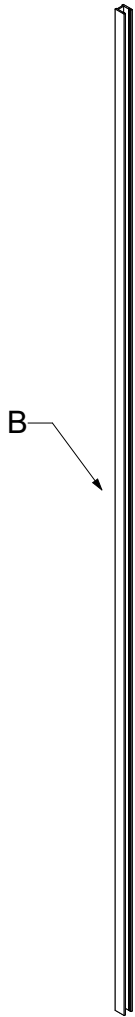

B

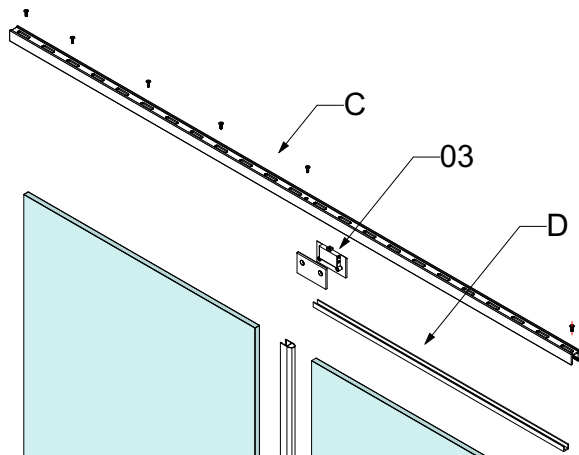

C

03

D

05

C

01

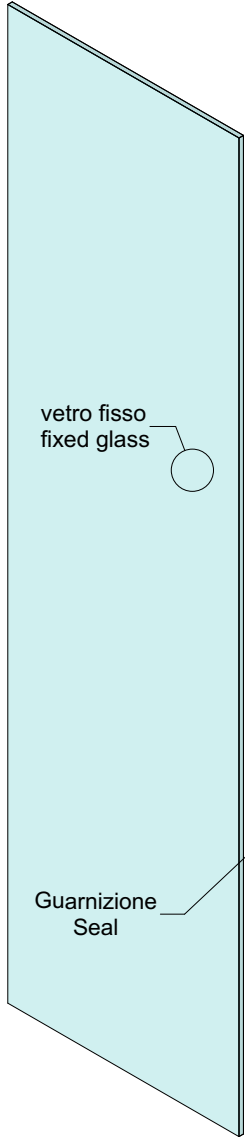

vetro fisso  
fixed glass

Guarnizione  
Seal

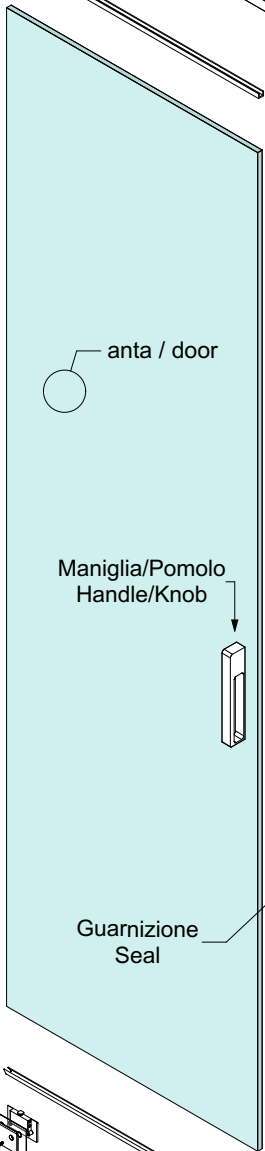

anta / door

Maniglia/Pomolo  
Handle/Knob

Guarnizione  
Seal

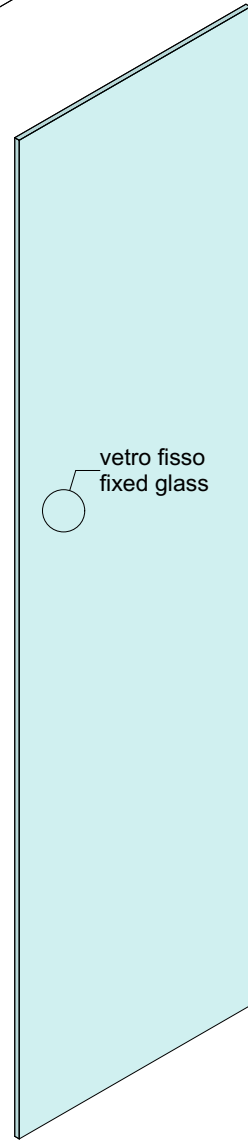

vetro fisso  
fixed glass



B

01

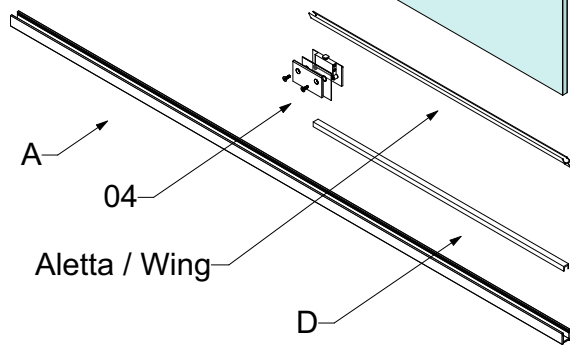

A

04

Aletta / Wing

D

05

A

01

Guarnizione / Seal



**PROFILI / PROFILE**

**A** BARRA INFERIORE

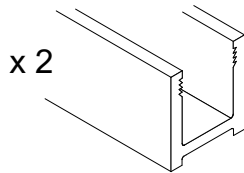

**B** VERT

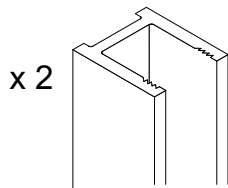

**C** BARRA SUPERIORE

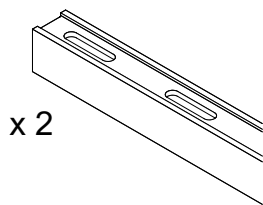

**D** COPRICAVA

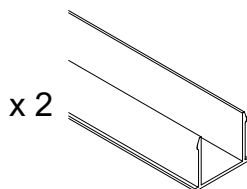

**INNESTI / JOINT**

**01** IN11

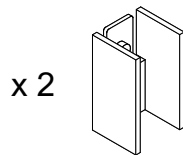

**02** IN11+IN09

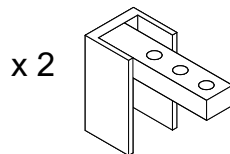

**03** CERNIERA SUPERIORE

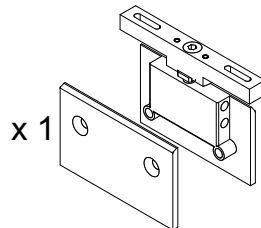

**04** CERNIERA INFERIORE

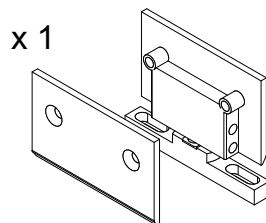

**05** PBLNS00502

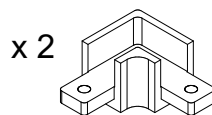

**GUARNIZIONI / SEAL**

PALLONCINO /  
BALOON SEAL  
GV04

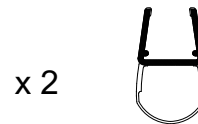

ALETTA / WING SEAL

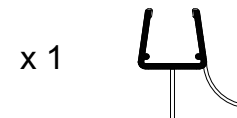

GUARNIZIONE PROFILO /  
PROFILE SEAL  
GS01



VITI FISSAGGIO  
FIXING SCREW

x 16



MANIGLIA-POMOLO  
HANDLE-KNOB

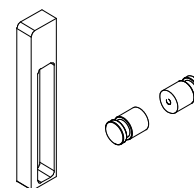

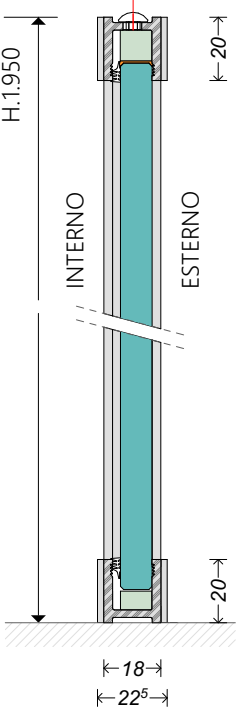
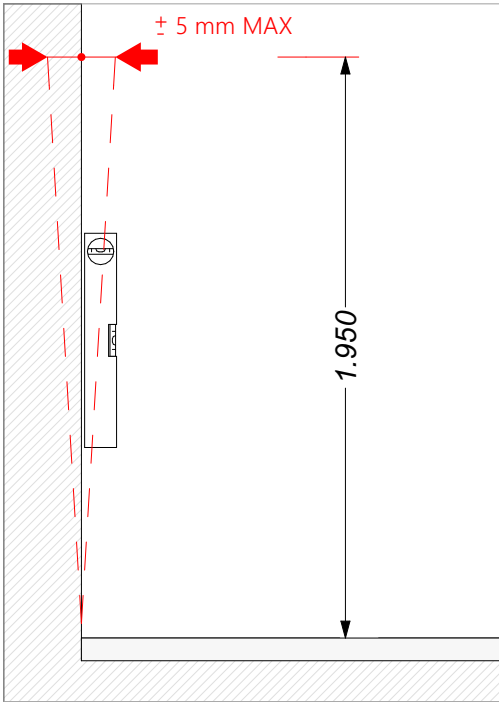
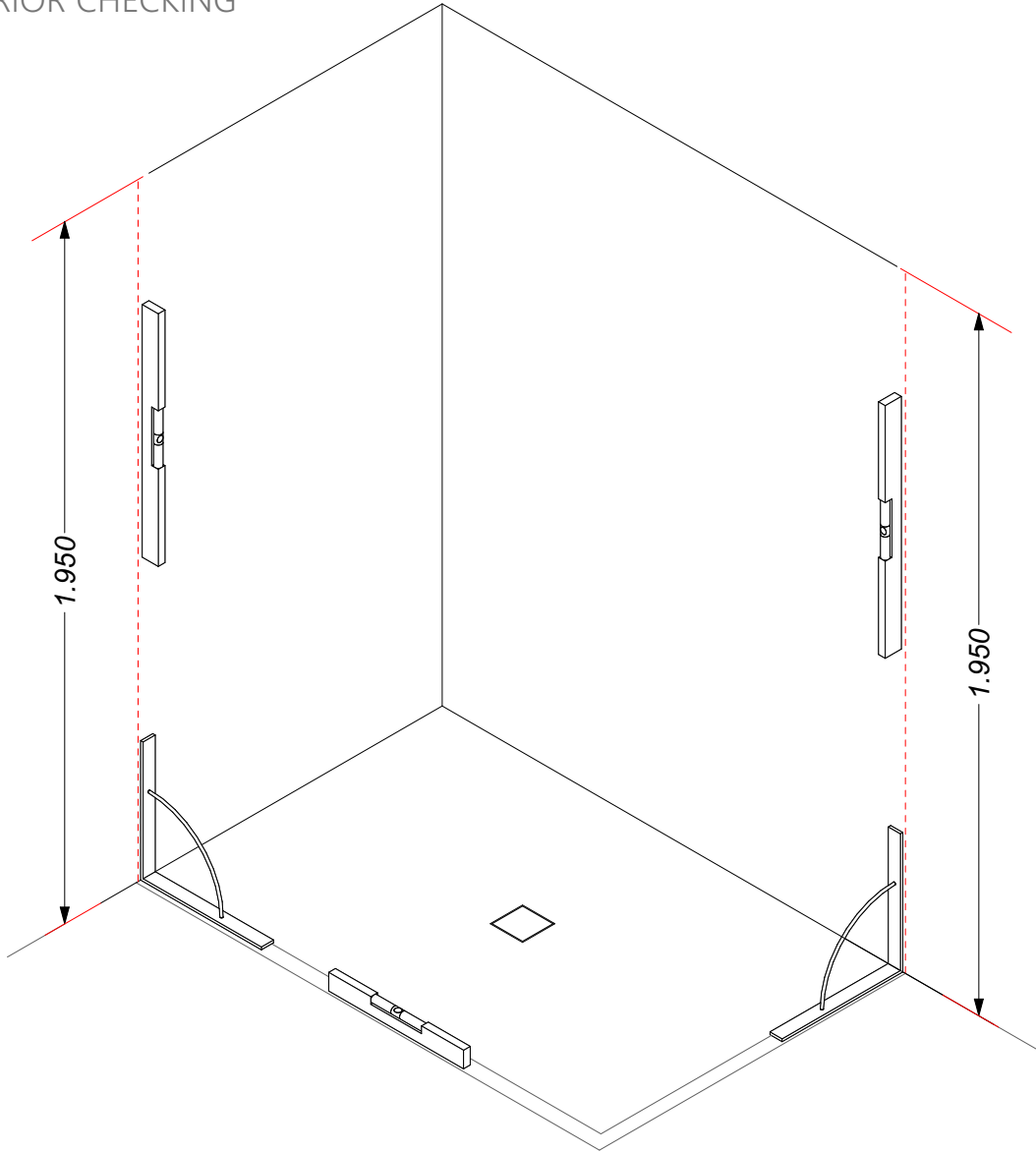





ATTENTION

Individuare il foro di montaggio del perno anta per posizionare correttamente il profilo a terra.

Find the hole for the door's hinge installation, in order to correctly locate the floor profile.

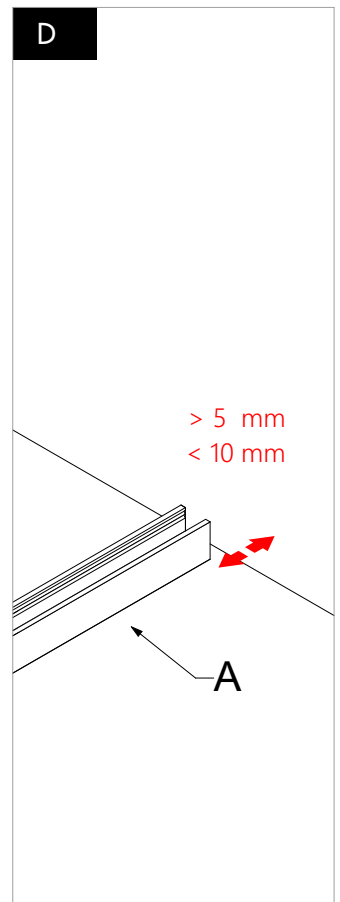
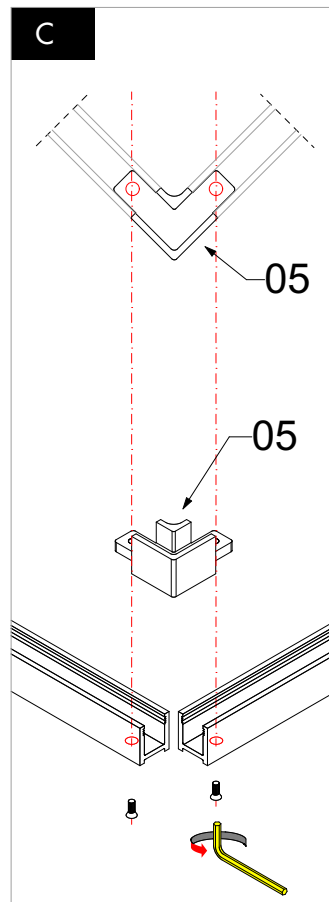
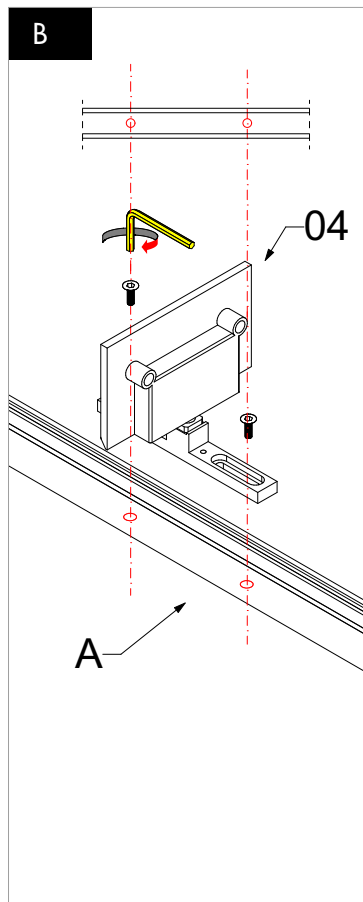
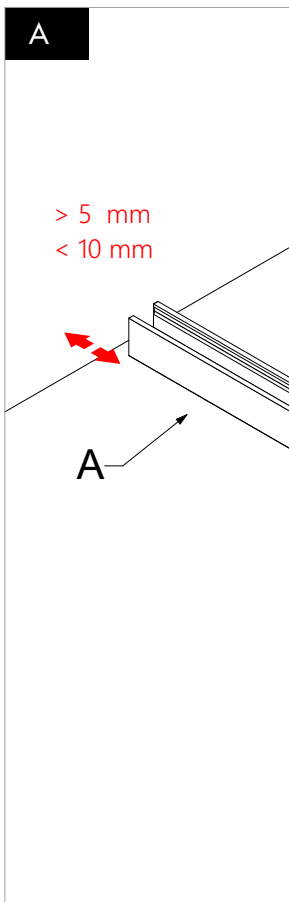
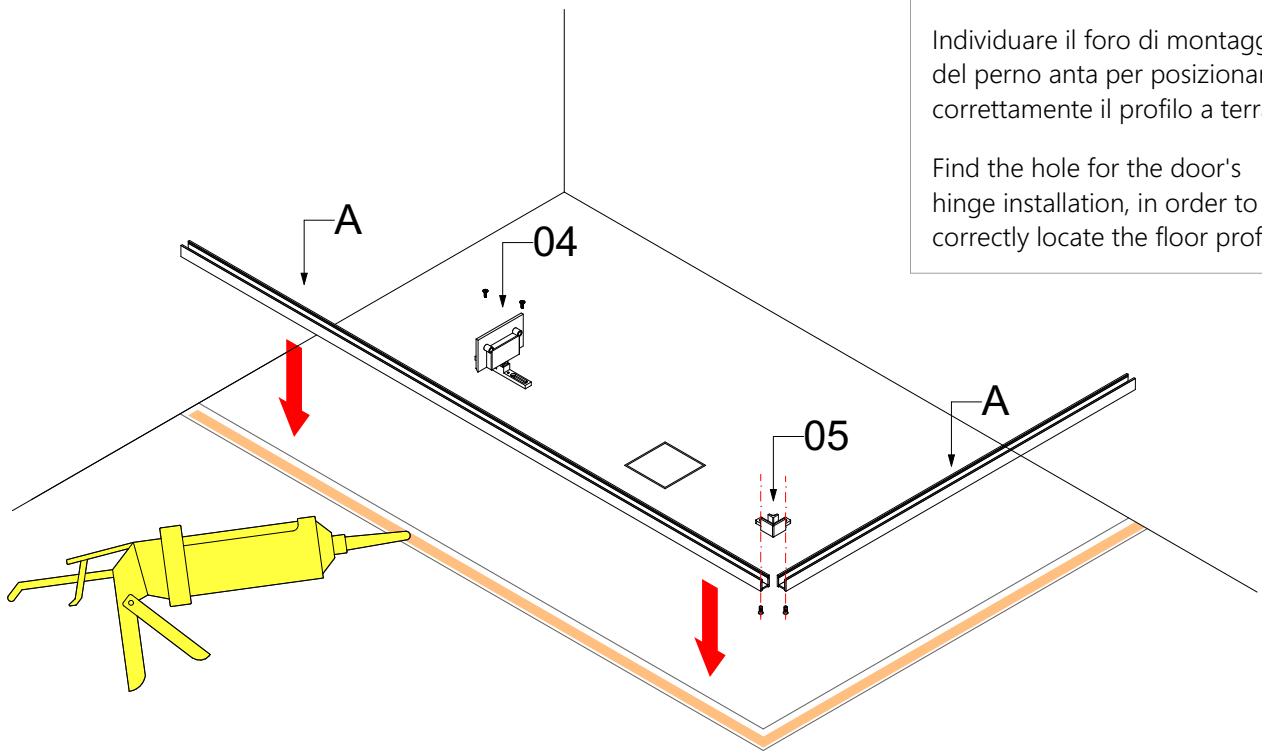

**⚠ ATTENTION**

Individuare il foro di montaggio del perno anta per posizionare correttamente il profilo.

Find the hole for the door's hinge installation, in order to correctly locate the floor profile.

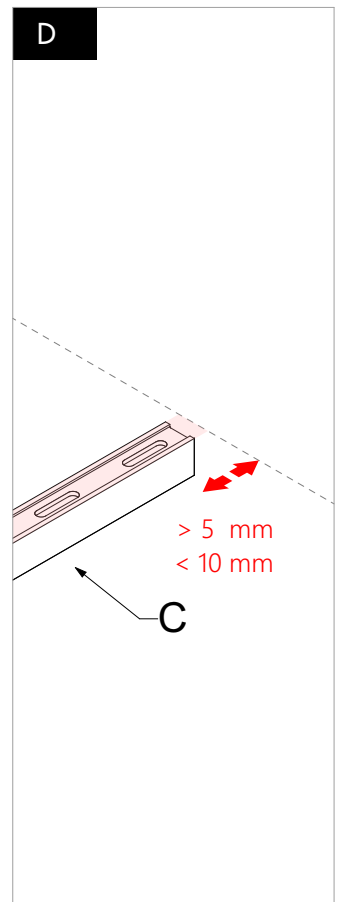
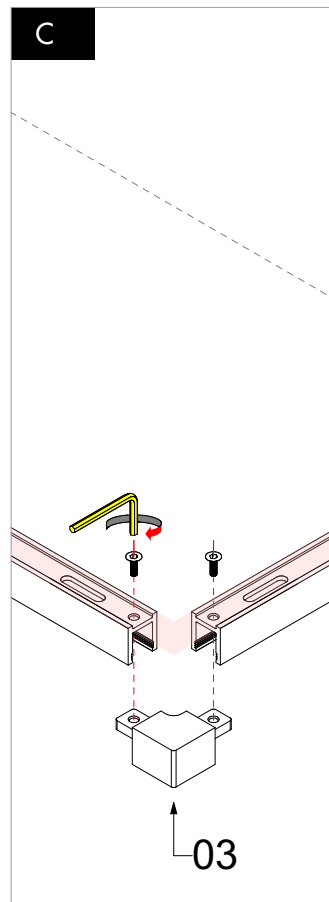
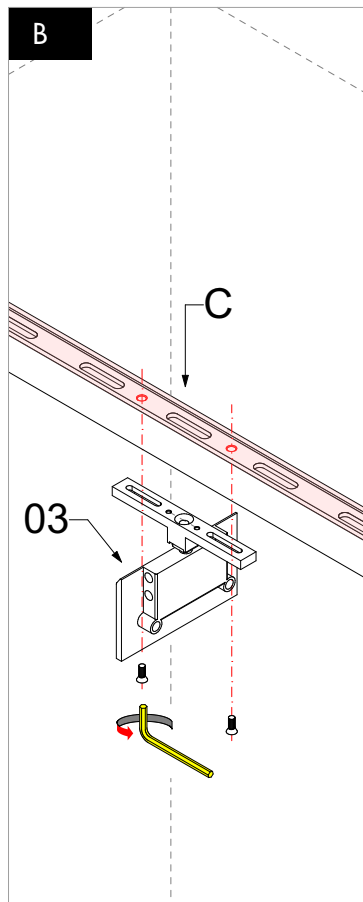
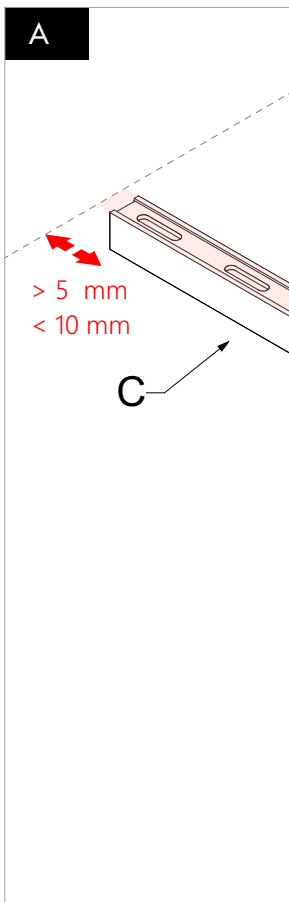
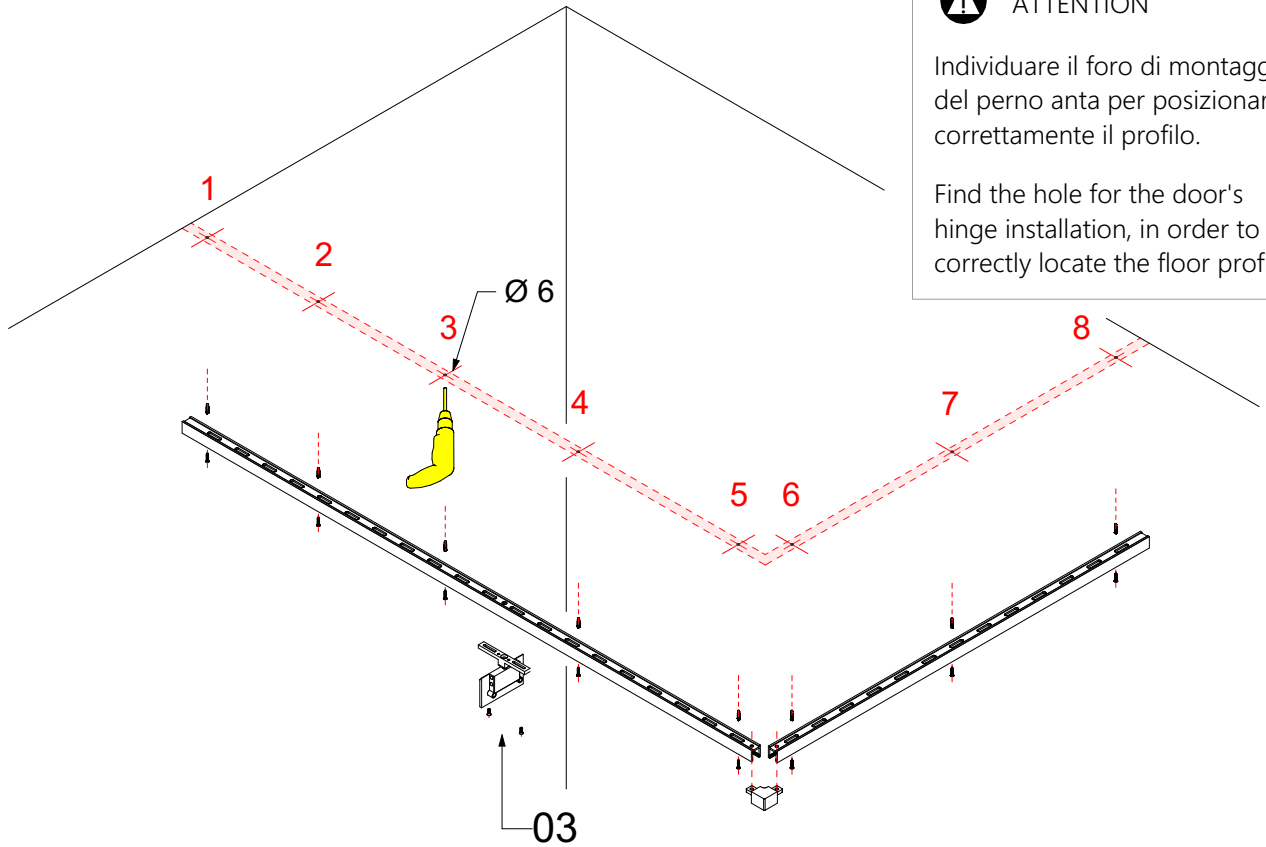



ATTENTION

Attenzione centratura tra innesti e profili.  
 - Pay attention to the grafts and profiles' centration.

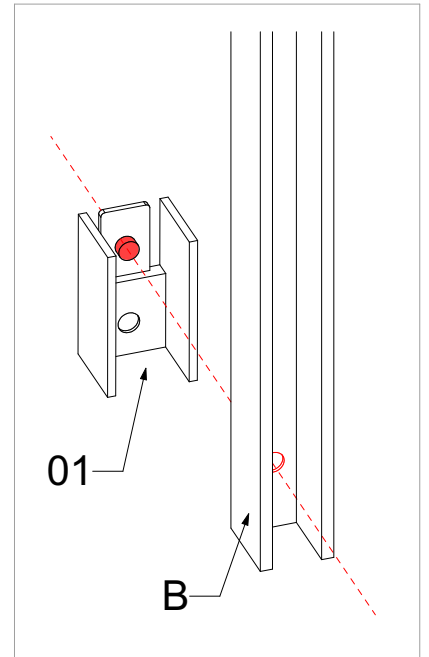
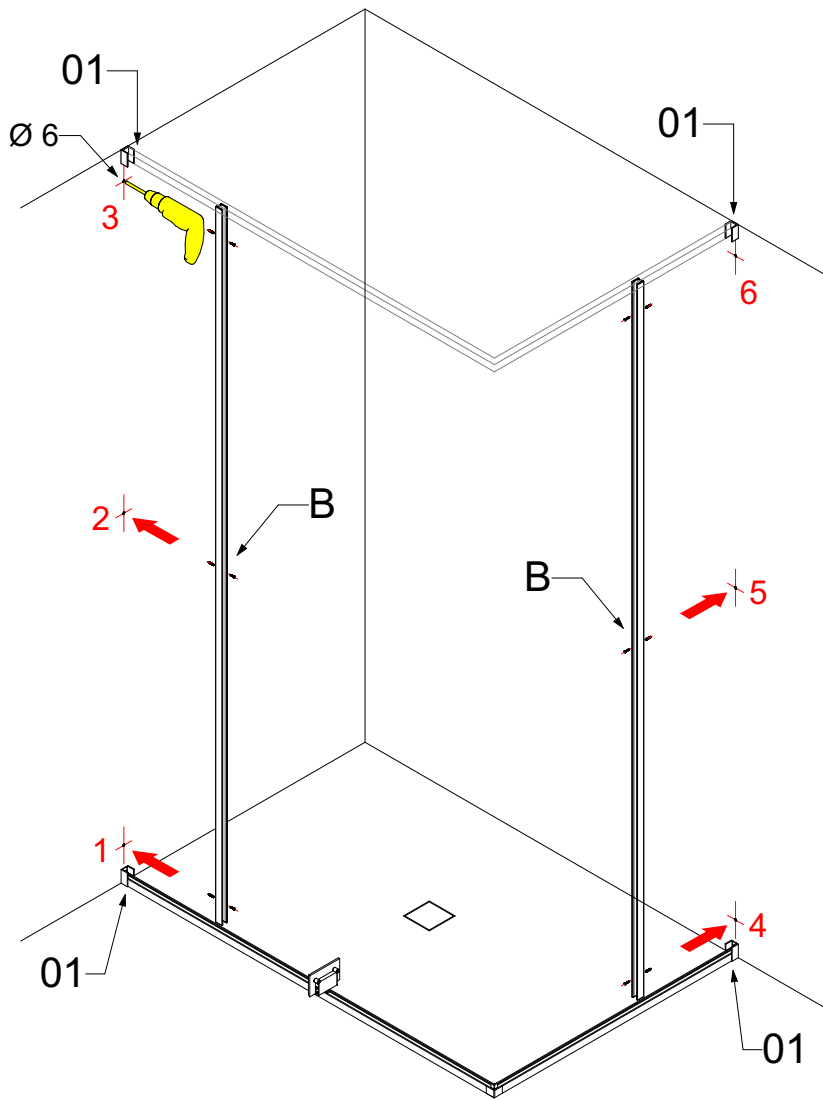

Sinistra / Left

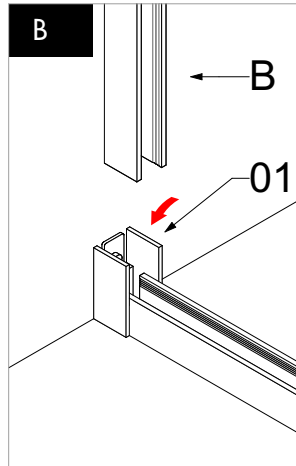
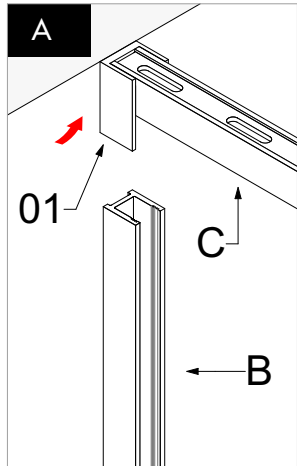

Destra / Right

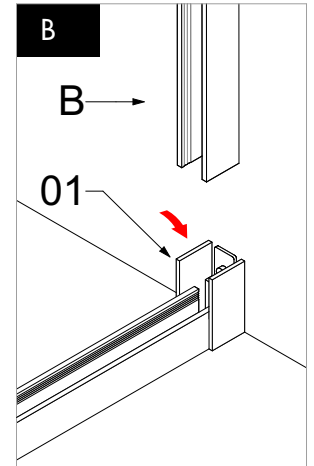
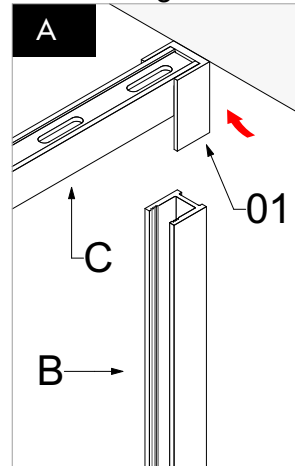



## ATTENTION

Attenzione silliconatura interna innesti.

- Put sylicone on the inner side of the grafts.

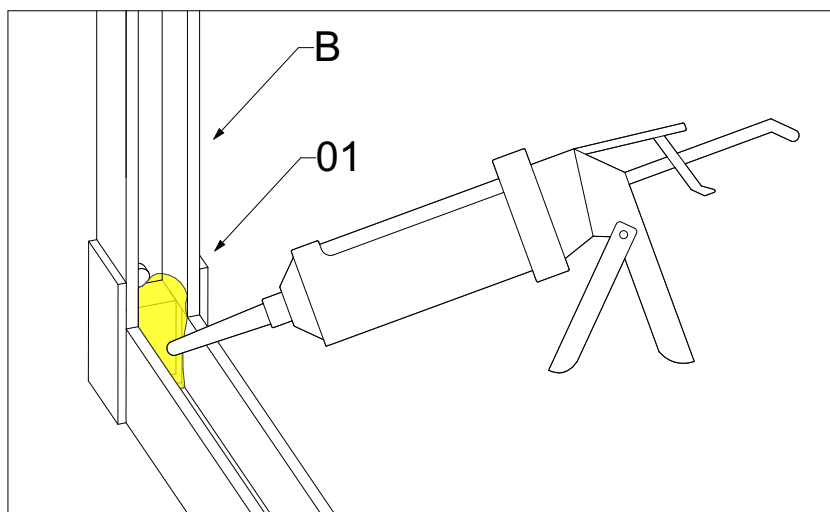
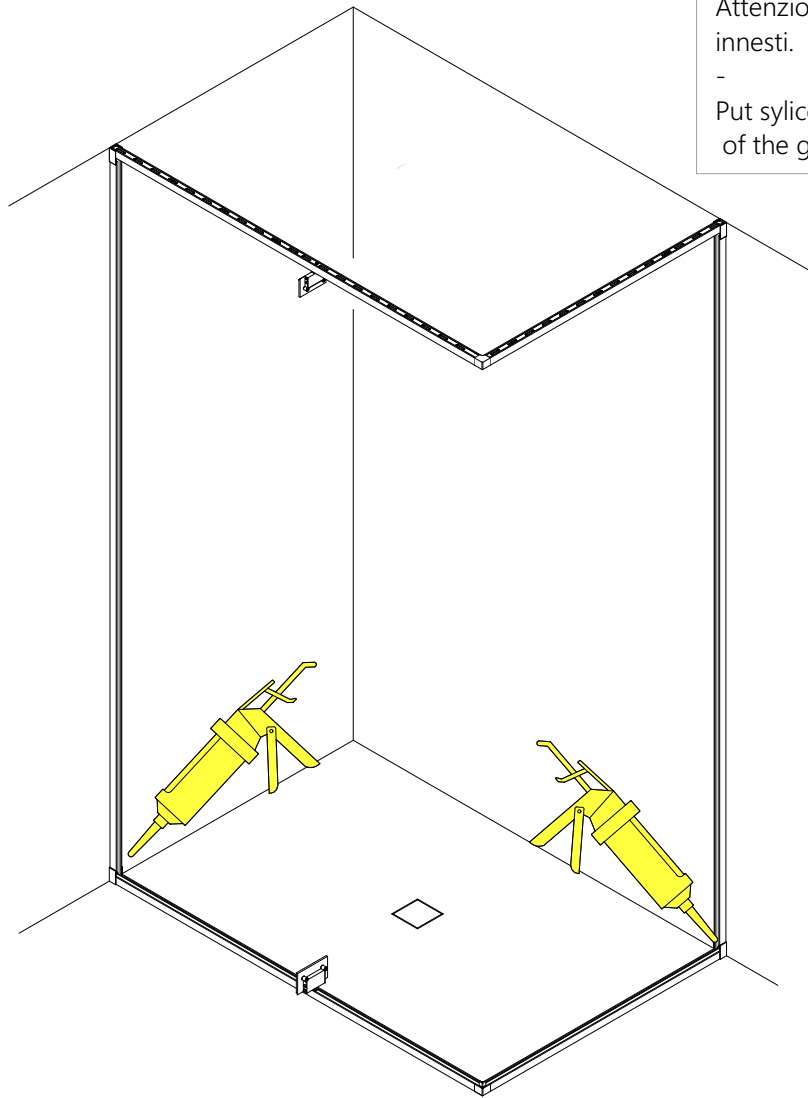

Vetro fisso / Fixed glass

A1

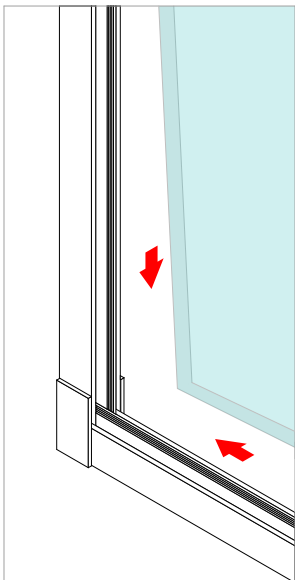
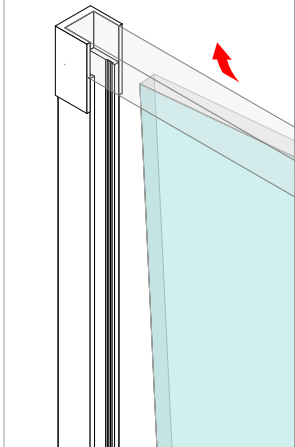

A2

Anta / Door

B1

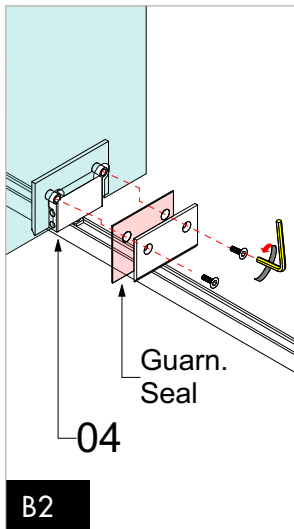
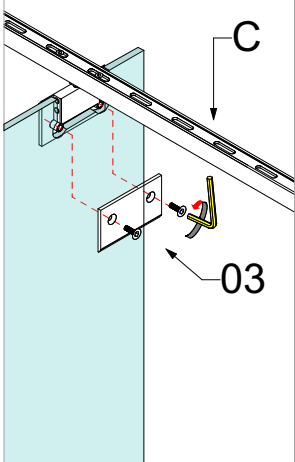

Attenzione applicare guarnizione tra vetro fisso e profilo sul lato interno, senza tagli nell'angolo inferiore.

- Install the gasket between the fixed glass and the inner side of the profile, do not cut on the lower corner.

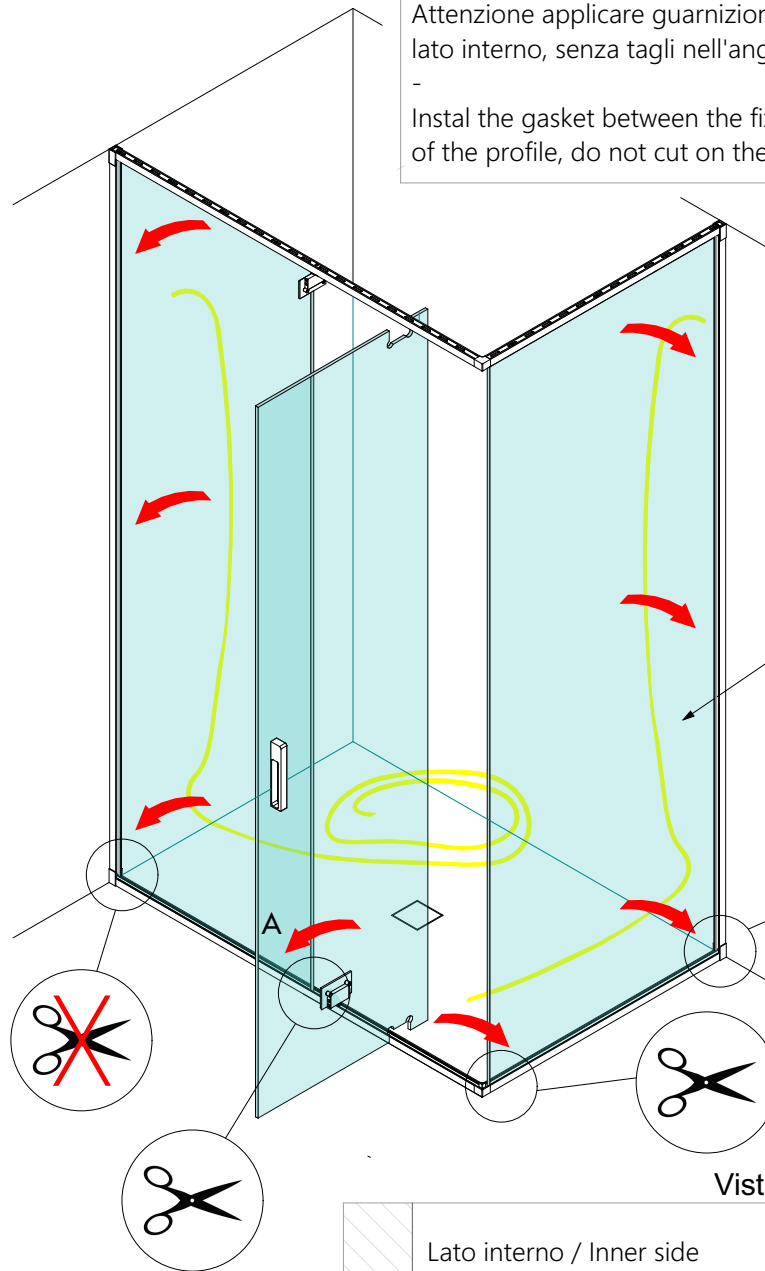

GUARNIZIONE PROFILO /  
PROFILE SEAL  
GS02

Vista dall'interno / Inside view

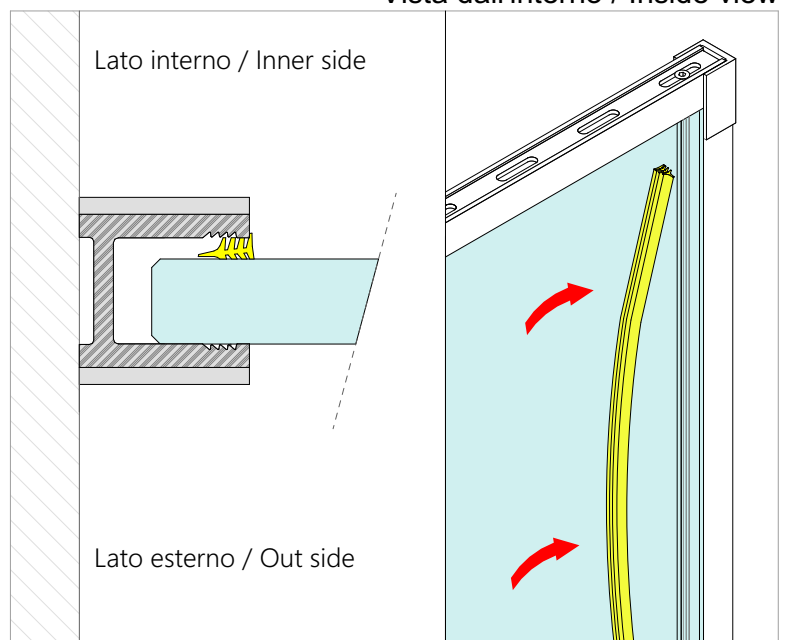

APPLICAZIONE SILICONATURA ESTERNA  
APPLY SYLICONE ON THE OUTER SIDES

  
Silicone neutro non acetico  
antimuffa  
-  
Neutral acetic anti-mold sylicone

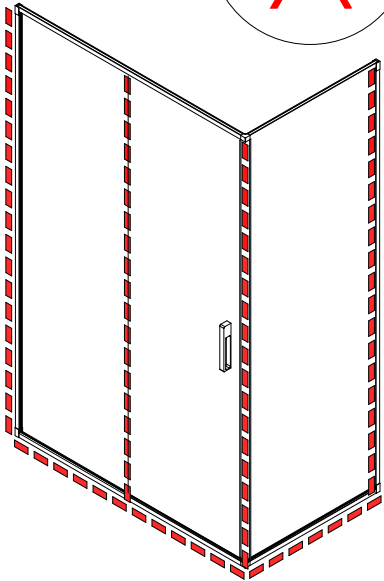
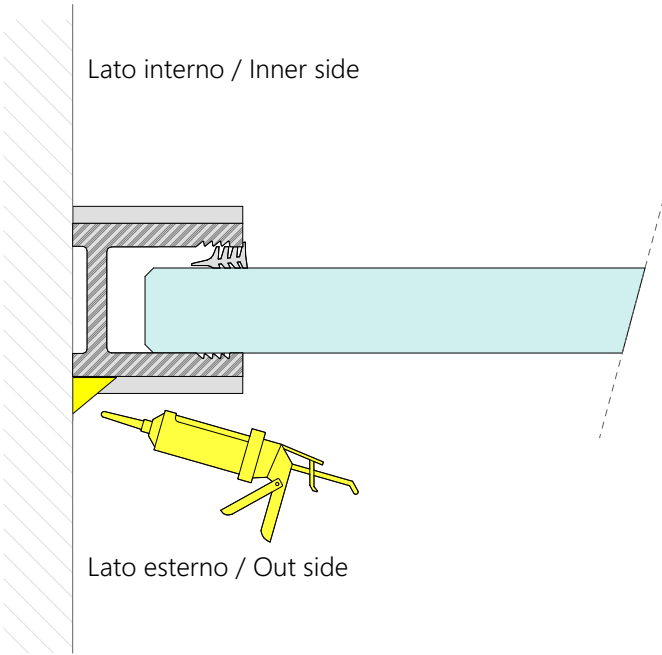
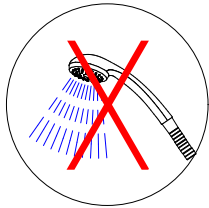
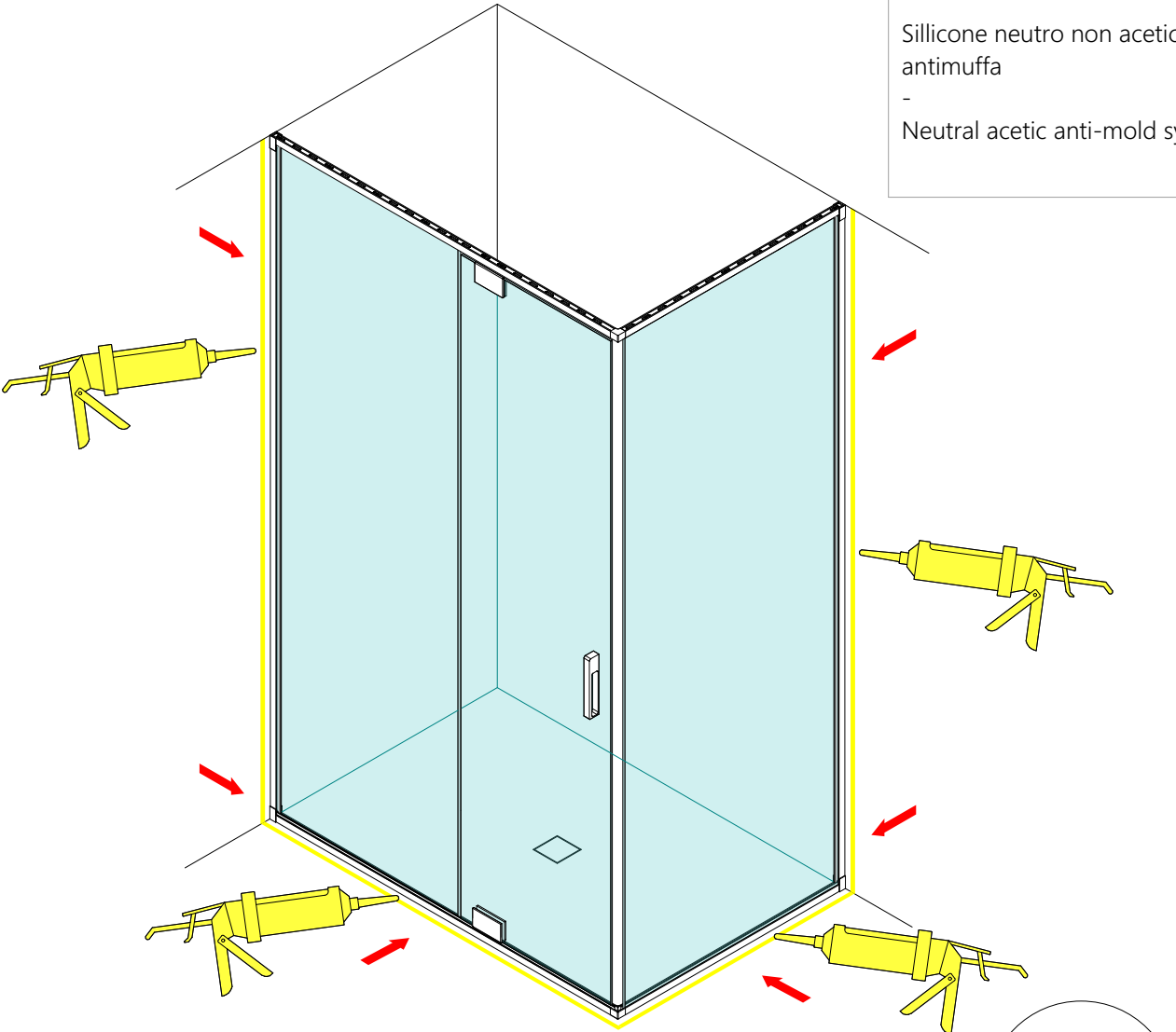

APPLICAZIONE GUARNIZIONI BATTENTE + STOP SUPERIORE  
INSTALLATION OF THE HINGED GASKET + UPPER LOCK

⚠  
Silicone neutro non acético  
antimuffa  
-  
Neutral acetic anti-mold silicone

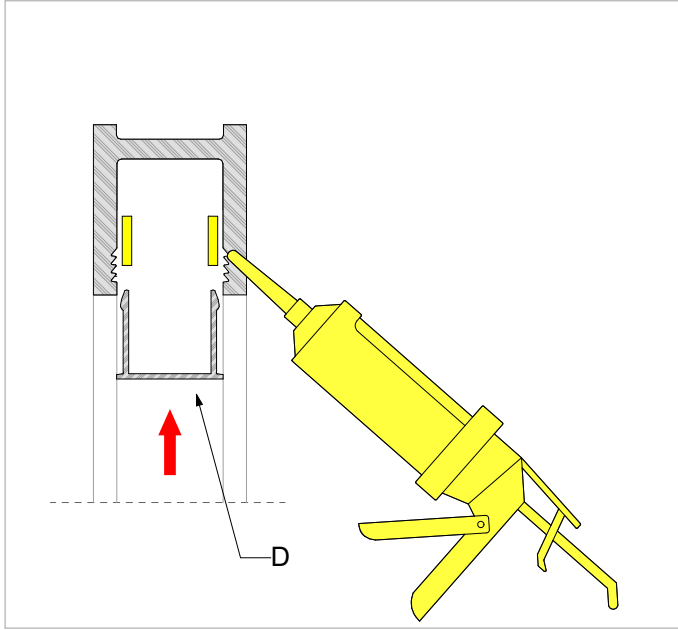
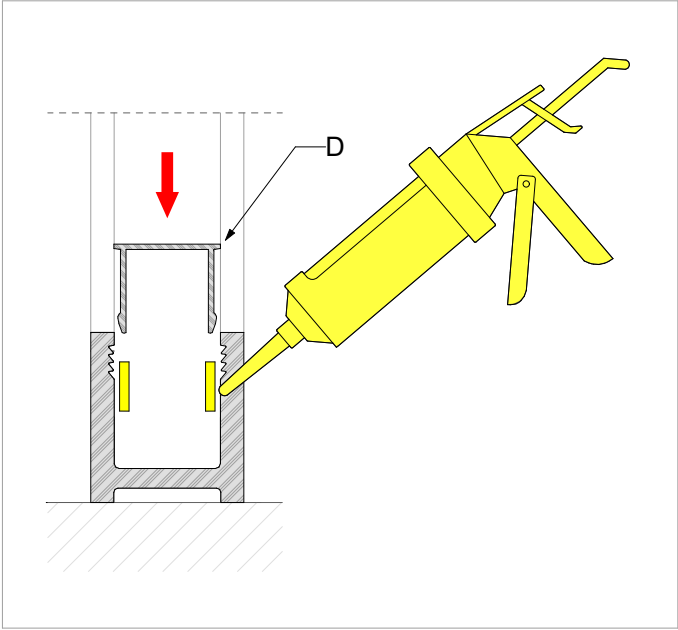
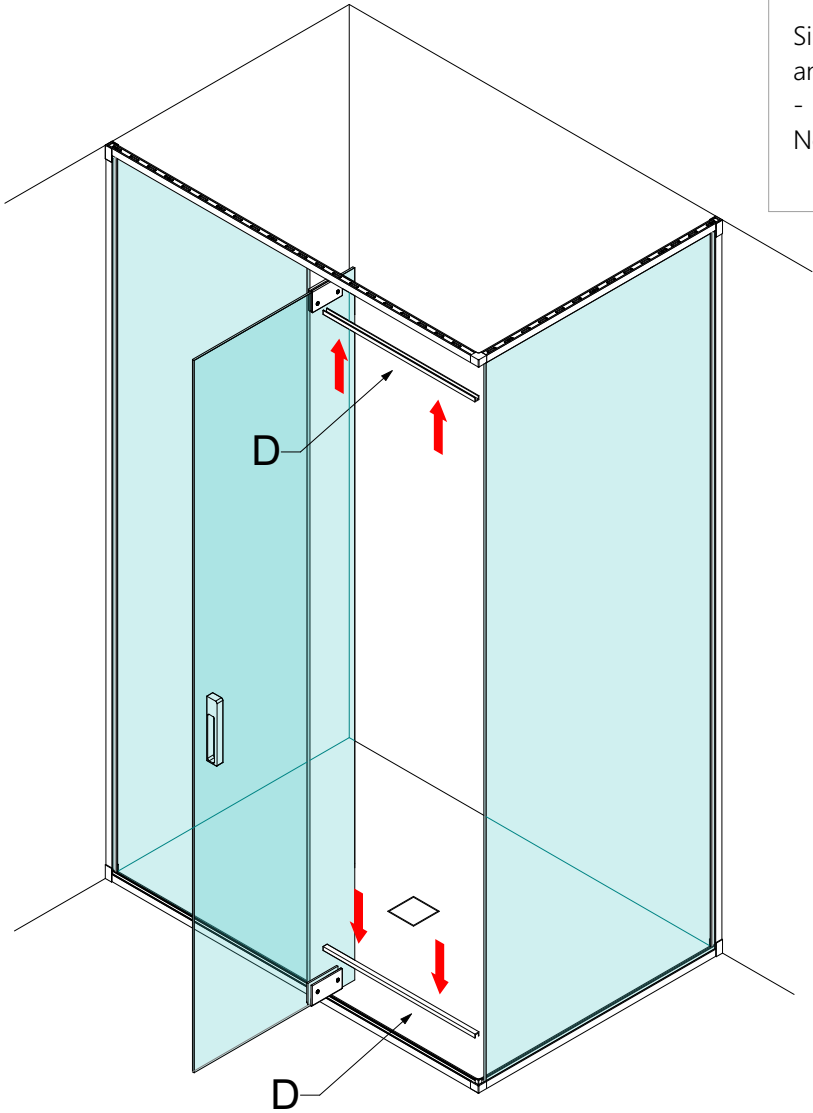

APPLICAZIONE COPRICAVA SUP. + INF.  
UPPER AND LOWER COVER INSTALLATION

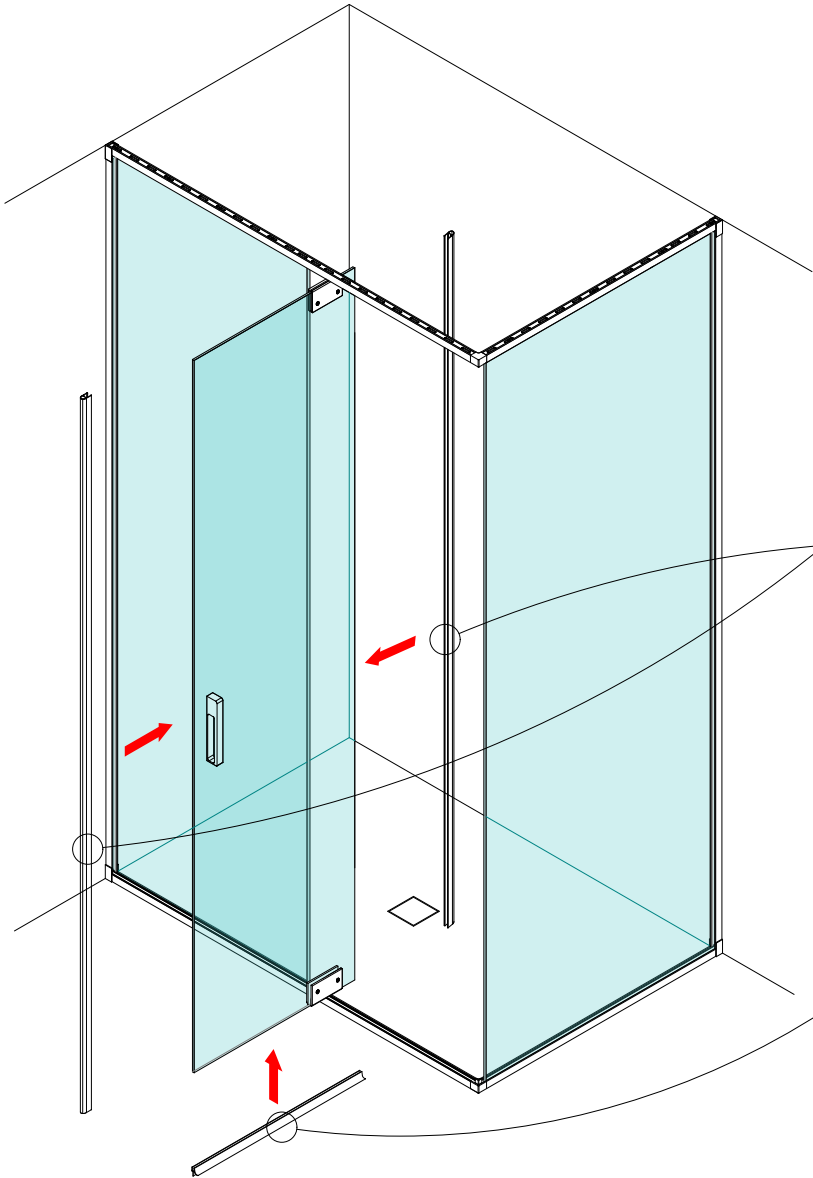

PALLONCINO /  
BALOON SEAL

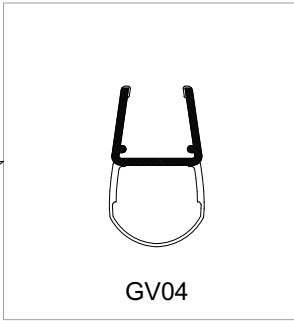

GV04

ALETTA / WING SEAL

